

AM/FM RADIO KIT

MODEL AM/FM-108CK SUPERHET RADIO
CONTAINS TWO SEPARATE AUDIO SYSTEMS:
IC AND TRANSISTOR

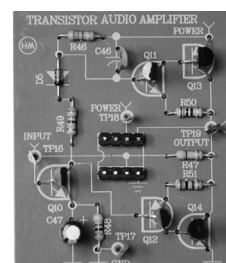

Assembly and Instruction Manual

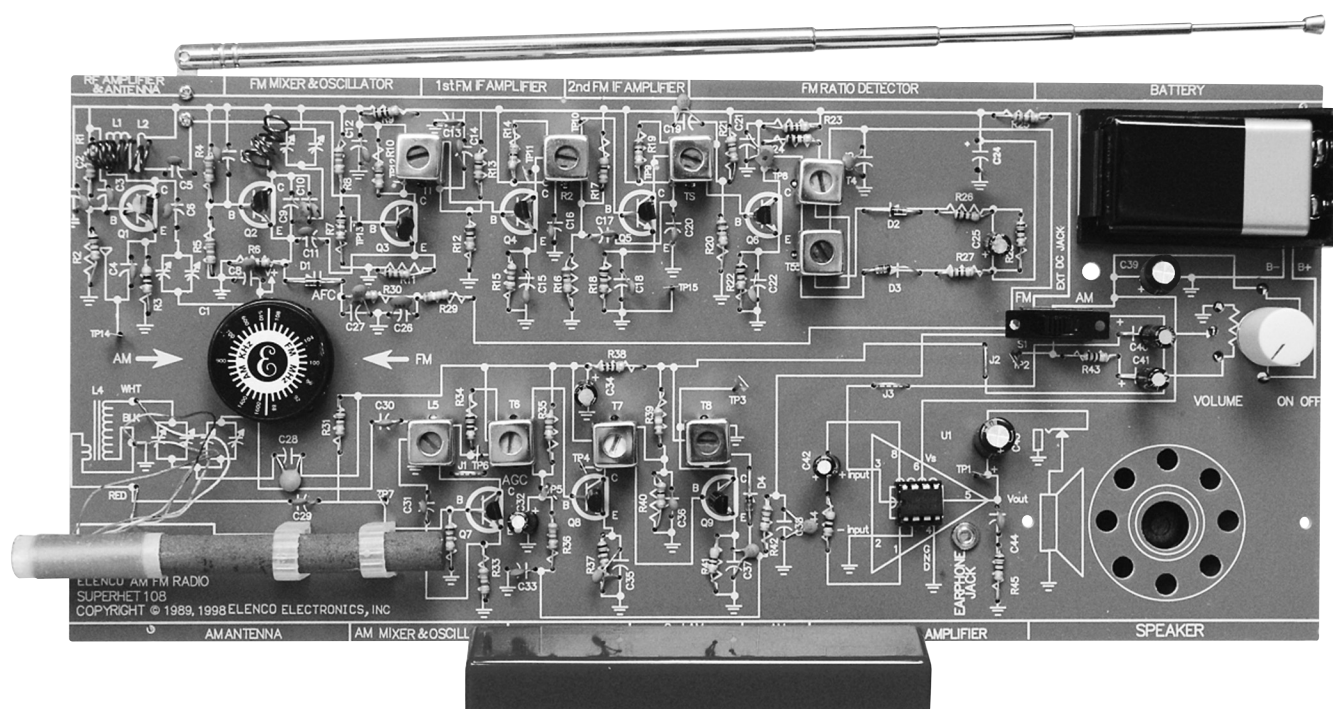

The AM/FM Radio project is divided into two parts, the AM Radio Section and the FM Radio Section. At this time, only identify the parts that you will need for the AM radio as listed below. DO NOT OPEN the bags listed for the FM radio. A separate parts list will be shown for the FM radio after you have completed the AM radio.

PARTS LIST FOR THE AM RADIO SECTION

If you are a student, and any parts are missing or damaged, please see instructor or bookstore.

If you purchased this kit from a distributor, catalog, etc., please contact ELENCO® (address/phone/e-mail is at the back of this manual) for additional assistance, if needed. **DO NOT** contact your place of purchase as they will not be able to help you.

RESISTORS

Qty.	Symbol	Value	Color Code	Part #
<input type="checkbox"/> 1	R45	10Ω 5% 1/4W	brown-black-black-gold	121000
<input type="checkbox"/> 2	R44, 48	47Ω 5% 1/4W	yellow-violet-black-gold	124700
<input type="checkbox"/> 4	R38, 43, 50, 51	100Ω 5% 1/4W	brown-black-brown-gold	131000
<input type="checkbox"/> 1	R49	330Ω 5% 1/4W	orange-orange-brown-gold	133300
<input type="checkbox"/> 1	R41	470Ω 5% 1/4W	yellow-violet-brown-gold	134700
<input type="checkbox"/> 1	R37	1kΩ 5% 1/4W	brown-black-red-gold	141000
<input type="checkbox"/> 1	R42	2.2kΩ 5% 1/4W	red-red-red-gold	142200
<input type="checkbox"/> 3	R33, 36, 46	3.3kΩ 5% 1/4W	orange-orange-red-gold	143300
<input type="checkbox"/> 1	R40	10kΩ 5% 1/4W	brown-black-orange-gold	151000
<input type="checkbox"/> 1	R32	12kΩ 5% 1/4W	brown-red-orange-gold	151200
<input type="checkbox"/> 1	R35	27kΩ 5% 1/4W	red-violet-orange-gold	152700
<input type="checkbox"/> 1	R39	39kΩ 5% 1/4W	orange-white-orange-gold	153900
<input type="checkbox"/> 1	R31	56kΩ 5% 1/4W	green-blue-orange-gold	155600
<input type="checkbox"/> 1	R47	470kΩ 5% 1/4W	yellow-violet-yellow-gold	164700
<input type="checkbox"/> 1	R34	1MΩ 5% 1/4W	brown-black-green-gold	171000
<input type="checkbox"/> 1	Volume/S2	50kΩ / SW	Potentiometer / switch with nut and plastic washer	192522

CAPACITORS

Qty.	Symbol	Value	Description	Part #
<input type="checkbox"/> 1	C30	150pF	Discap (151)	221510
<input type="checkbox"/> 1	C46	0.001μF	Discap (102)	244780
<input type="checkbox"/> 2	C31, 38	0.01μF	Discap (103)	241031
<input type="checkbox"/> 5	C29, 33, 35, 36, 37	0.02μF or 0.022μF	Discap (203) or (223)	242010
<input type="checkbox"/> 1	C44	0.047μF	Discap (473)	244780
<input type="checkbox"/> 2	C28, C45	0.1μF	Discap (104)	251010
<input type="checkbox"/> 4	C32, 40, 41, 42	10μF	Electrolytic radial (Lytic)	271045
<input type="checkbox"/> 1	C47	47μF	Electrolytic radial (Lytic)	274744
<input type="checkbox"/> 1	C34	100μF	Electrolytic radial (Lytic)	281044
<input type="checkbox"/> 2	C39, 43	470μF	Electrolytic radial (Non-Polarized)	284764
<input type="checkbox"/> 1	C1	Variable	Tuning gang AM/FM	299904

SEMICONDUCTORS

Qty.	Symbol	Value	Description	Part #
<input type="checkbox"/> 2	D4, 5	1N4148	Diode	314148
<input type="checkbox"/> 5	Q7, 8, 9, 10, 11	2N3904	Transistor NPN	323904
<input type="checkbox"/> 1	Q12	2N3906	Transistor PNP	323906
<input type="checkbox"/> 1	Q14	JE8050	Transistor NPN	328050
<input type="checkbox"/> 1	Q13	JE8550	Transistor PNP	328550
<input type="checkbox"/> 1	U1	LM386	Integrated circuit	330386

COILS

Qty.	Symbol	Color	Description	Part #
<input type="checkbox"/> 1	L5	Red	AM oscillator	430057
<input type="checkbox"/> 1	T6	Yellow	AM IF	430260
<input type="checkbox"/> 1	T7	White	AM IF	430262
<input type="checkbox"/> 1	T8	Black	AM IF	430264
<input type="checkbox"/> 1	L4		AM antenna with holders	484004

MAGIC WAND

Qty.	Description	Part #
<input type="checkbox"/> 1	Iron core	461000
<input type="checkbox"/> 1	Brass core	661150
<input type="checkbox"/> 4"	Shrink tubing	890120

PARTS LIST FOR THE AM RADIO SECTION (continued)





MISCELLANEOUS

Qty.	Description	Part #	Qty.	Description	Part #
□ 1	PC board, transistor audio amplifier	510007	□ 1	Earphone	629250
□ 1	PC board, main	517055	□ 3	Screw M1.8 x 7.5mm (battery holder)	641100
□ 1	Switch	541023	□ 1	Screw M2.5 x 7.5mm (dial)	641107
□ 1	Battery holder	590096	□ 2	Screw M2.5 x 3.8mm (gang)	641310
□ 1	Speaker	590102	□ 3	Nut M1.8	644210
□ 2	Header male 4-pin	591004	□ 1	Plastic washer	645108
□ 1	Speaker pad	780128	□ 1	Socket 8-pin	664008
□ 1	Knob (dial)	622040	□ 12	Test point pin	665008
□ 1	Knob (pot)	622050	□ 1	Label AM/FM	723059
□ 1	Earphone jack with nut	622130	□ 8"	Wire 22AWG insulated	814520
□ 1	Radio stand	626100	□ 1	Solder lead-free	9LF99

Note: The following parts are used in the Transistor Audio Amplifier Section (packaged in a separate bag) – R46, R47, R48, R49, R50, R51, C46, C47, D5, Q10, Q11, Q12, Q13, Q14, PC board (transistor audio amplifier), test point pin (qty. 4), and header male 4-pin (qty. 2).

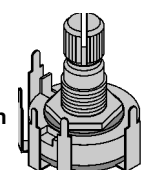
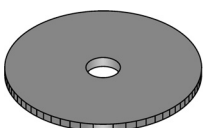
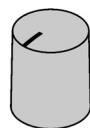
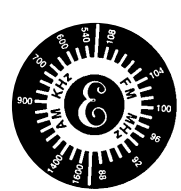
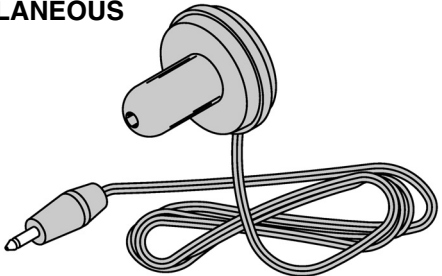
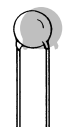
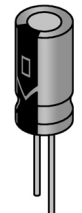
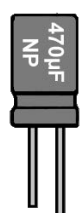
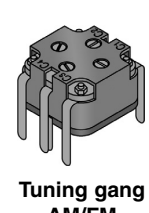
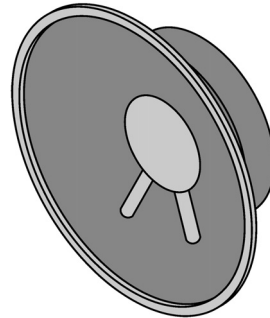
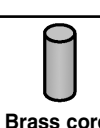
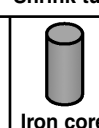
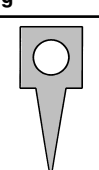
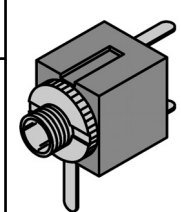
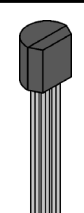
****** SAVE THE BOX THAT THIS KIT CAME IN. IT WILL BE USED ON PAGES 32 & 61. ******

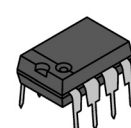
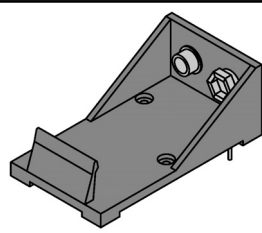
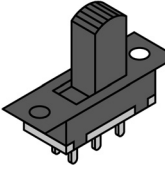
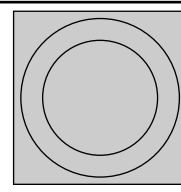
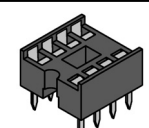
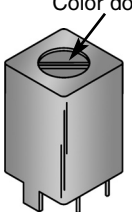
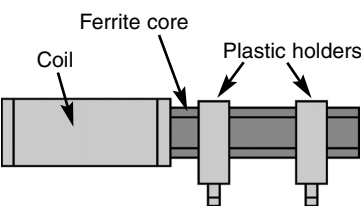
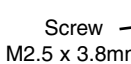
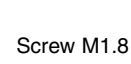
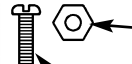
PARTS IDENTIFICATION

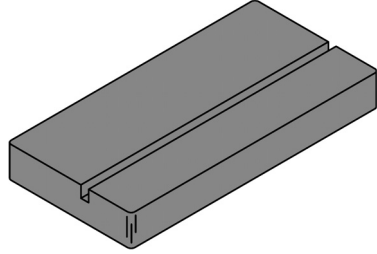
<p>RESISTORS</p>  <p>Carbon film</p>  <p>50kΩ Potentiometer / switch with nut, metal washer, and plastic washer</p>	<p>MISCELLANEOUS</p>  <p>Knob (dial)</p>  <p>Knob (pot)</p>  <p>Label AM/FM</p>  <p>Earphone</p>	
<p>CAPACITORS</p>  <p>Discap</p>  <p>Electrolytic Radial</p>  <p>Non-Polarized Electrolytic Radial</p>  <p>470µF NP Tuning gang AM/FM</p>	 <p>Speaker</p>	<p>Shrink tubing</p>  <p>Brass core</p>  <p>Iron core</p>  <p>Test point pin</p>  <p>Earphone jack with nut</p>
<p>SEMICONDUCTORS</p>  <p>Transistor</p>  <p>Diode</p>  <p>LM386 IC</p>	 <p>Battery holder</p>	 <p>Slide switch</p>  <p>Speaker pad</p>  <p>8-pin Socket</p>
<p>COILS</p>  <p>Coil</p>  <p>Antenna Assembly</p>	<p>Hardware</p>  <p>Screw M2.5 x 3.8mm</p>  <p>Screw M1.8 x 7.5mm</p>  <p>Nut M1.8</p>  <p>Screw M2.5 x 7.5mm</p>  <p>Radio stand</p>	

IDENTIFYING RESISTOR VALUES

Use the following information as a guide in properly identifying the value of resistors.

BAND 1 1st Digit	
Color	Digit
Black	0
Brown	1
Red	2
Orange	3
Yellow	4
Green	5
Blue	6
Violet	7
Gray	8
White	9

BAND 2 2nd Digit	
Color	Digit
Black	0
Brown	1
Red	2
Orange	3
Yellow	4
Green	5
Blue	6
Violet	7
Gray	8
White	9

Multiplier	
Color	Multiplier
Black	1
Brown	10
Red	100
Orange	1,000
Yellow	10,000
Green	100,000
Blue	1,000,000
Silver	0.01
Gold	0.1

Resistance Tolerance	
Color	Tolerance
Silver	±10%
Gold	±5%
Brown	±1%
Red	±2%
Orange	±3%
Green	±0.5%
Blue	±0.25%
Violet	±0.1%

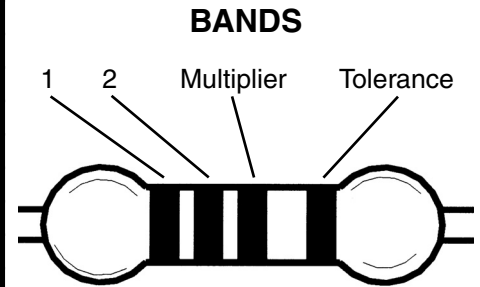

IDENTIFYING CAPACITOR VALUES

Capacitors will be identified by their capacitance value in pF (picofarads), nF (nanofarads), or μF (microfarads). Most capacitors will have their actual value printed on them. Some capacitors may have their value printed in the following manner. The maximum operating voltage may also be printed on the capacitor.

Multiplier	For the No.	0	1	2	3	4	5	8	9
	Multiply By	1	10	100	1k	10k	100k	.01	0.1

The value is:

$$10 \times 1,000 = 10,000\text{pF or } .01\mu\text{F } 100\text{V}$$

* The letter M indicates a tolerance of $\pm 20\%$
 The letter K indicates a tolerance of $\pm 10\%$
 The letter J indicates a tolerance of $\pm 5\%$

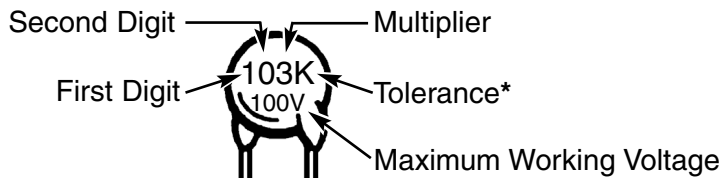

Note: The letter "R" may be used at times to signify a decimal point; as in 3R3 = 3.3

Electrolytic capacitors

have a positive and a negative electrode. The negative lead is indicated on the packaging by a stripe with minus signs and possibly arrowheads. Also, the negative lead of a radial electrolytic is shorter than the positive one.

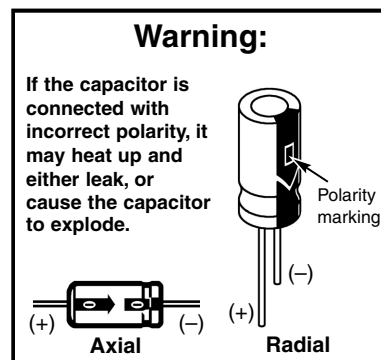

Non-Polarized capacitors

(C24,C39,C43) are capacitors without positive or negative polarity. The two electrodes of non-polarized capacitors can be randomly inserted into the circuit, and will not leak.

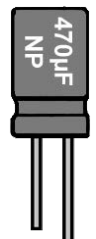

METRIC UNITS AND CONVERSIONS

Abbreviation	Means	Multiply Unit By	Or
p	Pico	.000000000001	10^{-12}
n	nano	.000000001	10^{-9}
μ	micro	.000001	10^{-6}
m	milli	.001	10^{-3}
—	unit	1	10^0
k	kilo	1,000	10^3
M	mega	1,000,000	10^6

1. 1,000 pico units	= 1 nano unit
2. 1,000 nano units	= 1 micro unit
3. 1,000 micro units	= 1 milli unit
4. 1,000 milli units	= 1 unit
5. 1,000 units	= 1 kilo unit
6. 1,000 kilo units	= 1 mega unit

INTRODUCTION

The Elenco® Superhet 108C AM/FM Radio Kit is a “superheterodyne” receiver of the standard AM (amplitude modulation) and FM (frequency modulation) broadcast frequencies. The unique design of the Superhet 108 allows you to place the parts over their corresponding symbol in the schematic drawing on the surface of the printed circuit board during assembly. This technique maximizes the learning process while keeping the chances of an assembly error at a minimum. It is very important, however, that good soldering practices are used to prevent bad connections. The Soldering Guide should be reviewed before any soldering is attempted.

The actual assembly is broken down into 9 sections. The theory of operation for each section, or stage, should be read before the assembly is started. This will provide the student

with an understanding of what that stage has been designed to accomplish, and how it actually works. After each assembly, you will be instructed to make certain tests and measurements to prove that each section is functioning properly. If a test fails to produce the proper results, a troubleshooting guide is provided to help you correct the problem. If test equipment is available, further measurements and calculations are demonstrated to allow each student to verify that each stage meets the engineering specifications. After all of the stages have been built and tested, a final alignment procedure is provided to peak the performance of the receiver and maximize the Superhet 108's reception capabilities.

GENERAL DISCUSSION

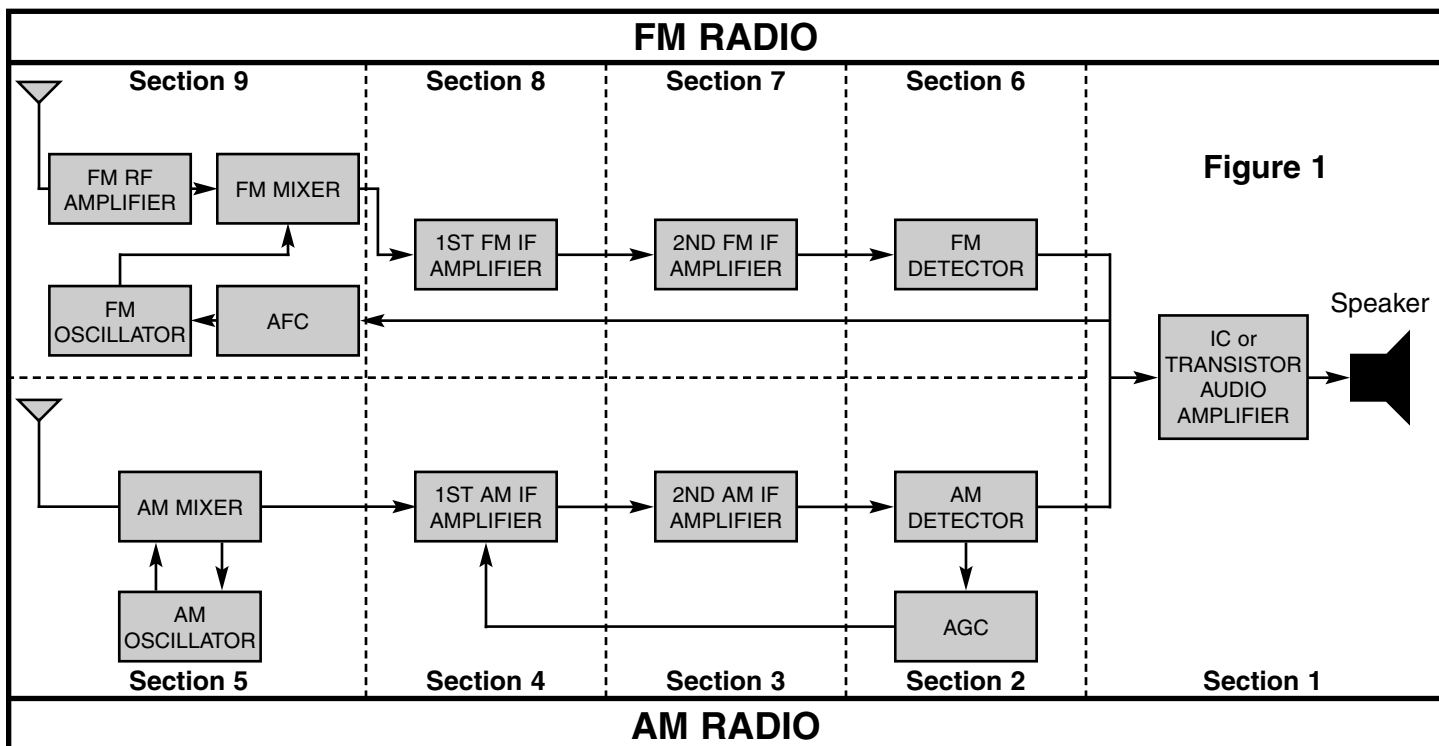

The purpose of Section 1, the Audio Amplifier Stage, is to increase the power of the audio signal received from either detector to a power level capable of driving the speaker. The audio amplifier is IC or transistor version. Section 2 includes the AM detector circuit and the AGC (automatic gain control) stage. The AM detector converts the amplitude modulated IF (intermediate frequency) signal to a low level audio signal. The AGC stage feeds back a DC voltage to the first AM IF amplifier in order to maintain a near constant level of audio at the detector. Section 3 is the second AM IF amplifier. The second AM IF amplifier is tuned to 455kHz (Kilohertz) and has a fixed gain at this frequency of 50. Section 4 is the first AM IF 2 amplifier which has a variable gain that depends on the AGC voltage received from the AGC stage. The first AM IF amplifier is also tuned to 455kHz. Section 5 includes the AM mixer, AM oscillator and AM antenna stages. When the radio wave passes through the antenna, it induces a small voltage across the antenna coil. This voltage is coupled to the mixer, or converter, stage to be changed to a frequency of 455kHz. This change is accomplished by mixing (heterodyning) the radio frequency signal with the oscillator

signal. Section 6 is the FM ratio detector circuit. The FM ratio detector has a fixed gain of about 20. Section 7 is the second FM IF amplifier. The second FM IF amplifier is tuned to 10.7MHz (Megahertz) and has a set gain of approximately 20. The 3dB bandwidth of this stage should be approximately 350kHz. Section 8 is the first FM IF amplifier. The first FM IF amplifier is also tuned to 10.7MHz and has a set gain of approximately 10. It also has a 3dB bandwidth of 350kHz. Section 9 includes the FM mixer, FM oscillator, FM RF (Radio Frequency) amplifier, AFC (Automatic Frequency Control) stage, and the FM antenna. The incoming radio waves are amplified by the FM RF amplifier, which is tuned to a desired radio station in the FM frequency bandwidth of 88MHz to 108MHz. These amplified signals are then coupled to the FM mixer stage to be changed to a frequency of 10.7MHz. This change, as in AM, is accomplished by heterodyning the radio frequency signal with the oscillator signal. The AFC stage feeds back a DC voltage to the FM oscillator to prevent the oscillator from drifting. Each of these blocks will be explained in detail in the Theory of Operation given before the assembly instructions for that stage.

CONSTRUCTION

Introduction

The most important factor in assembling your Superhet 108C AM/FM Radio Kit is good soldering techniques. Using the proper soldering iron is of prime importance. A small pencil type soldering iron of 25 watts is recommended. **The tip of the iron must be kept clean at all times and well tinned.**

Solder

For many years leaded solder was the most common type of solder used by the electronics industry, but it is now being replaced by lead-free solder for health reasons. This kit contains lead-free solder, which contains 99.3% tin, 0.7% copper, and has a rosin-flux core.

Lead-free solder is different from lead solder: It has a higher melting point than lead solder, so you need higher temperature for the solder to flow properly. Recommended tip temperature is approximately 700°F; higher temperatures improve solder flow but accelerate tip decay. An increase in soldering time may be required to achieve good results. Soldering iron tips wear out faster since lead-free solders are more corrosive and the higher soldering temperatures accelerate corrosion, so proper tip care is important. The solder joint finish will look slightly duller with lead-free solders.

Use these procedures to increase the life of your soldering iron tip when using lead-free solder:

- Keep the iron tinned at all times.
- Use the correct tip size for best heat transfer. The conical tip is the most commonly used.

- Turn off iron when not in use or reduce temperature setting when using a soldering station.
- Tips should be cleaned frequently to remove oxidation before it becomes impossible to remove. Use Dry Tip Cleaner (Elenco® #SH-1025) or Tip Cleaner (Elenco® #TTC1). If you use a sponge to clean your tip, then use distilled water (tap water has impurities that accelerate corrosion).

Safety Procedures

- **Always wear safety glasses or safety goggles to protect your eyes when working with tools or soldering iron, and during all phases of testing.** 
- Be sure there is **adequate ventilation** when soldering.
- Locate soldering iron in an area where you do not have to go around it or reach over it. Keep it in a safe area away from the reach of children.
- **Do not hold solder in your mouth.** Solder is a toxic substance. Wash hands thoroughly after handling solder.

Assemble Components

In all of the following assembly steps, the components must be installed on the top side of the PC board unless otherwise indicated. The top legend shows where each component goes. The leads pass through the corresponding holes in the board and are soldered on the foil side.

Use only rosin core solder.

DO NOT USE ACID CORE SOLDER!

What Good Soldering Looks Like

A good solder connection should be bright, shiny, smooth, and uniformly flowed over all surfaces.

1. Solder all components from the copper foil side only. Push the soldering iron tip against both the lead and the circuit board foil.

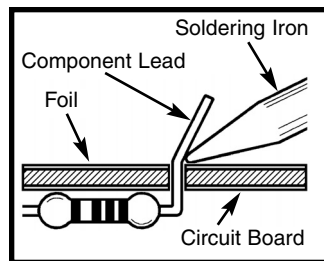

2. Apply a small amount of solder to the iron tip. This allows the heat to leave the iron and onto the foil. Immediately apply solder to the opposite side of the connection, away from the iron. Allow the heated component and the circuit foil to melt the solder.

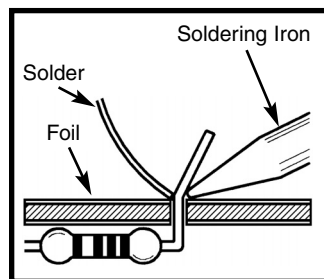

3. Allow the solder to flow around the connection. Then, remove the solder and the iron and let the connection cool. The solder should have flowed smoothly and not lump around the wire lead.

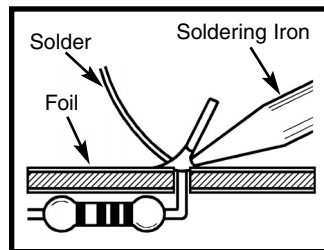

4. Here is what a good solder connection looks like.

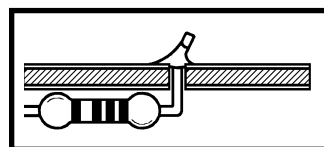

Types of Poor Soldering Connections

1. **Insufficient heat** - the solder will not flow onto the lead as shown.

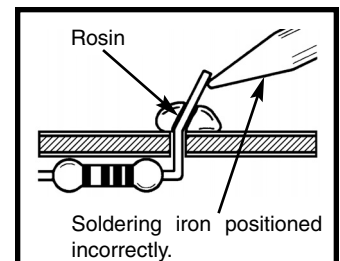

2. **Insufficient solder** - let the solder flow over the connection until it is covered. Use just enough solder to cover the connection.

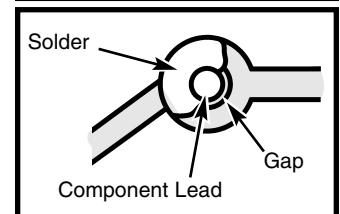

3. **Excessive solder** - could make connections that you did not intend to between adjacent foil areas or terminals.

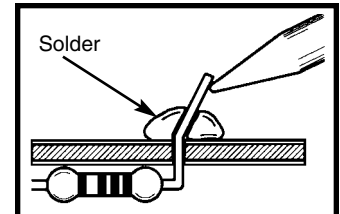

4. **Solder bridges** - occur when solder runs between circuit paths and creates a short circuit. This is usually caused by using too much solder. To correct this, simply drag your soldering iron across the solder bridge as shown.

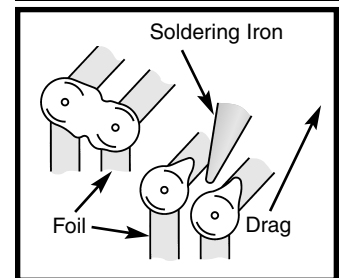

SEMICONDUCTOR PARTS FAMILIARIZATION

This section will familiarize you with the proper method used to test the transistors and the diode.

TRANSISTOR TEST (NPN and PNP)

Refer to the parts list and find a NPN transistor. Refer to the Figure J (page 16) for locating the Emitter, Base and Collector. Using an Ohmmeter, connect the transistor as shown in Test A. Your meter should be reading a low resistance. Switch the lead from the Emitter to the Collector. Your meter should again be reading a low resistance.

Using an Ohmmeter, connect the transistor as shown in Test B. Your meter should be reading a high resistance. Switch the lead from the Emitter to the Collector. Your meter should again be reading a high resistance. Typical results read approximately $1M\Omega$ to infinity.

Refer to parts list and find a PNP transistor, refer to Figure K (page 16) for locating the Emitter, Base and Collector. Using an Ohmmeter, connect the transistor as shown in Test C. Your meter should be reading a low resistance. Switch the lead from the Emitter to the Collector. Your meter should again be reading a low resistance.

Using an Ohmmeter, connect the transistor as shown in Test D. Your meter should be reading a high resistance. Switch the lead from the Emitter to the Collector. Your meter should again be reading a high resistance.

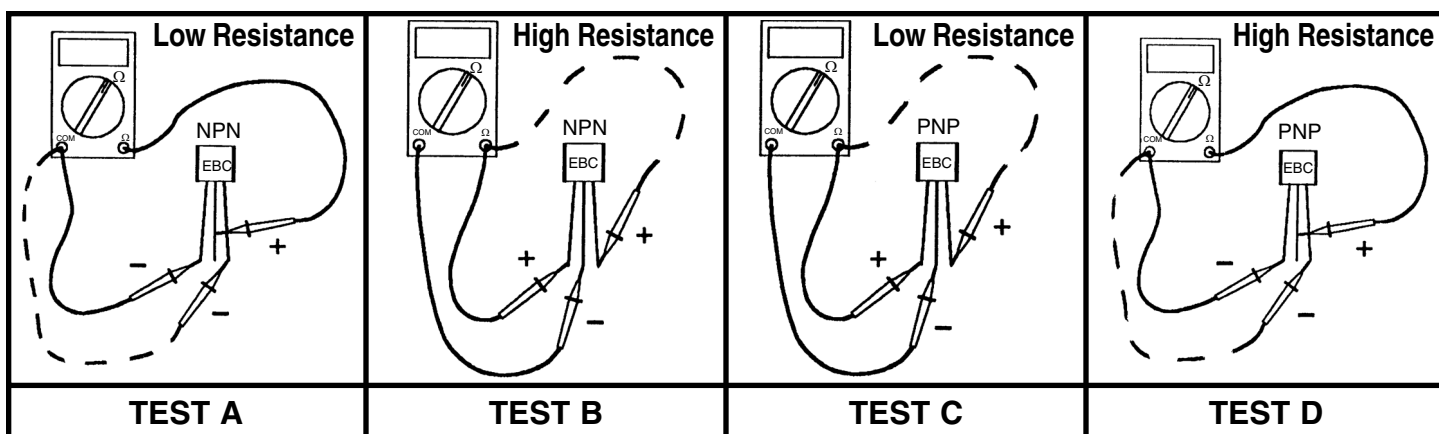

DIODE TEST

Refer to the parts list and find a diode. Refer to Figure H (page 16) for locating the Cathode and Anode. The end with the band is the cathode. Using an Ohmmeter, connect the diode as shown in Test E. Your meter should be reading a low resistance. Using an Ohmmeter,

connect the diode as shown in Test F. Your meter should be reading a high resistance. Typical results read approximately $1M\Omega$ to infinity for silicon diodes (1N4148).

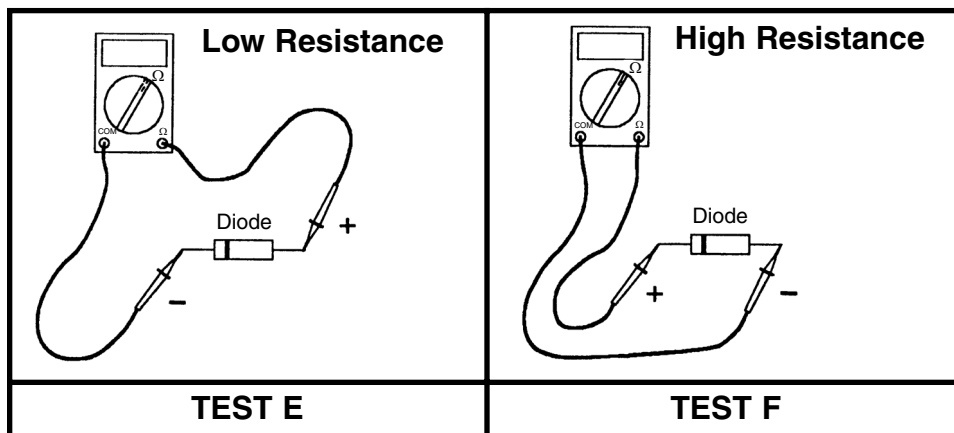

SECTION 1A

INTEGRATED CIRCUIT (IC) AUDIO AMPLIFIER

This radio kit contains two separate audio systems. The first is an integrated circuit (IC) and the second is a five-transistor circuit. The objective is to show you how these two circuits function and to compare the performance of each. We will begin the radio project by building the IC audio amplifier first.

The purpose of the Audio Amplifier is to increase the audio power to a level sufficient to drive an 8 ohm speaker. To do this, DC (direct current) from the battery is converted by the amplifier to an AC (alternating current) in the speaker. The ratio of the power delivered to the speaker and the power taken from the battery is the efficiency of the amplifier. For the Audio Amplifier, we use the integrated circuit (IC) LM-386. In Figure 2, you can see equivalent schematic and connection diagrams.

In a Class A amplifier (transistor on over entire cycle), the maximum theoretical efficiency is 0.5 or 50%. But, in a Class B amplifier (transistor on for 1/2 cycle), the maximum theoretical efficiency is 0.785 or 78.5%. Since transistor characteristics are not ideal in a pure Class B amplifier, the transistors will introduce crossover distortion. This is due to the non-linear transfer curve near zero current or cutoff. This type of distortion is shown in Figure 3.

In order to eliminate crossover distortion and maximize efficiency, the transistors of the audio amplifier circuit are biased on for slightly more than 1/2 of the cycle, Class AB. In other words, the transistors are working as Class A amplifiers for very small levels of power to the speaker, but they slide toward Class B operation at larger power levels.

To make the LM-386 a more versatile amplifier, two pins (1 and 8) are provided for gain control. With pins 1 and 8 open, the 1.35kΩ resistor sets the gain at 20 (see Figure 4a). The

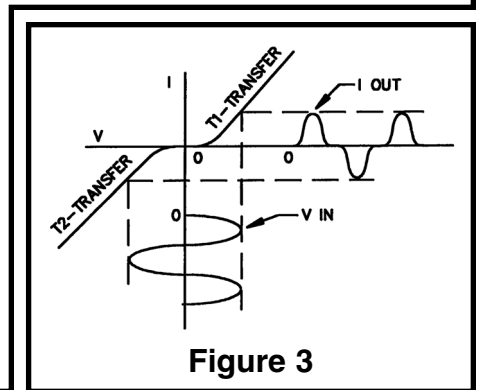
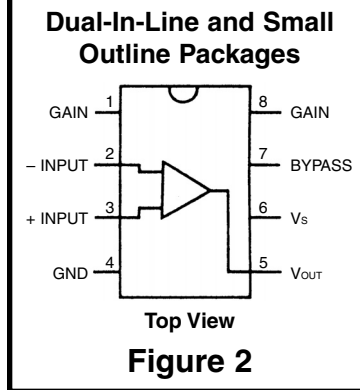
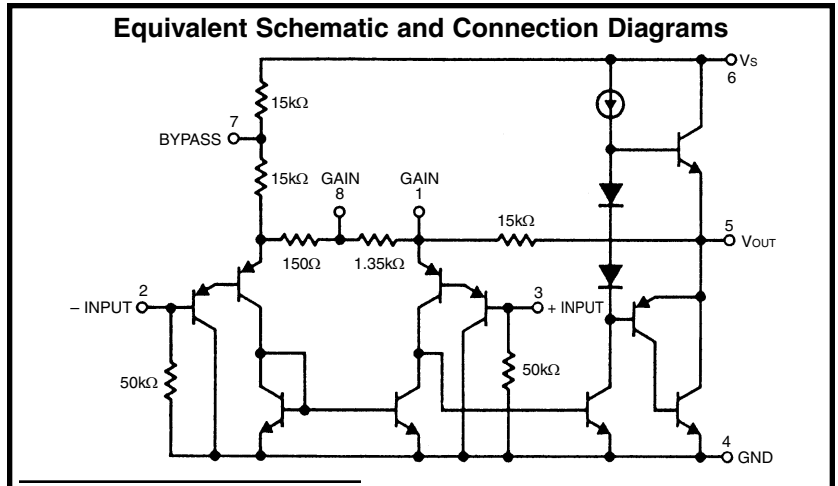

gain will go up to 200 (see Figure 4b) if a capacitor is placed between pins 1 and 8. The gain can be set to any value from 20 to 200 if a resistor is placed in series with the capacitor. The amplifier with a gain of 150 is shown in Figure 4c.

The amplifier in our kit with a gain of 150 is shown in Figure 5. Capacitor C40 couples the audio signal from the volume control to the input of the audio amplifier. Capacitor C43 blocks the DC to the speaker, while allowing the AC to pass.

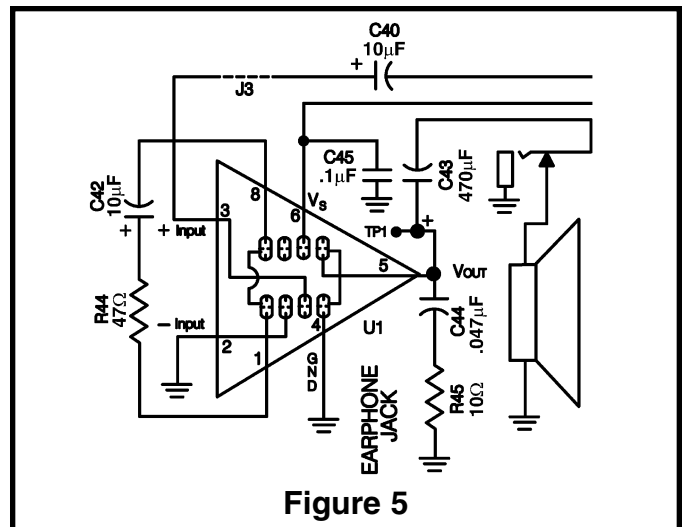
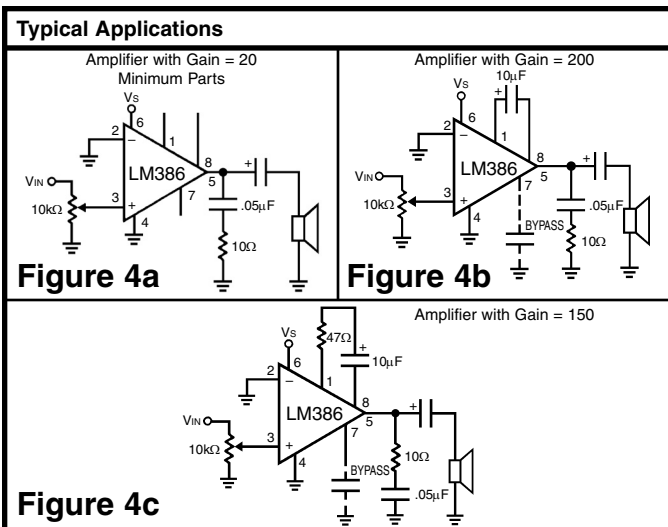

ASSEMBLY INSTRUCTIONS

We will begin by installing resistor R43. Identify the resistor by its color and install as shown on page 4. Be careful to properly mount and solder all components. Diodes, transistors and electrolytic capacitors are polarized, be sure to follow the instructions carefully so that they are not mounted backwards. Check the box when you have completed each installation.

Wear safety goggles during all assembly stages in this manual. 

Test Point Pin

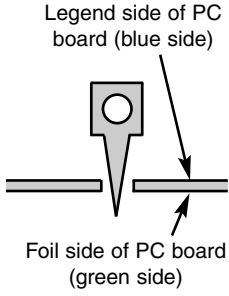

Legend side of PC board (blue side)

Foil side of PC board (green side)

Figure A

Lytic Capacitor

Be sure that the negative (short) lead is in the correct hole on the PC board.

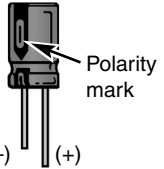

Polarity mark

(-) (+)

Warning:
If the capacitor is connected with incorrect polarity, it may heat up and either leak, or cause the capacitor to explode.

Figure B

Non-Polarized Capacitor

The capacitor is non-polarized, insert leads in either direction.

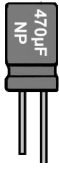

Figure C

Integrated Circuit (IC)

- Insert the IC socket into the PC board with the notch in the same direction as the marking on the top legend (blue side). Solder the IC socket into place.
- Insert the IC into the socket with the notch or dot in the same direction as the notch on the socket.

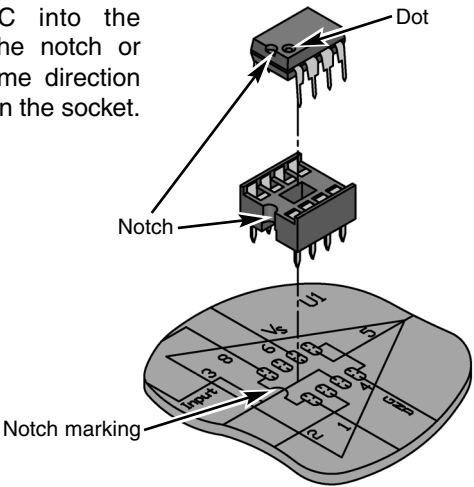
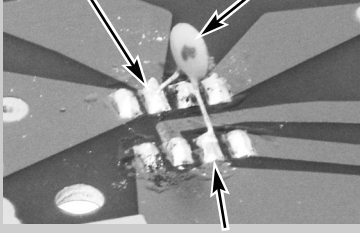

Figure D

- R43 - 100Ω Resistor (brown-black-brown-gold)
- TP2 - Test Point Pin (see Figure A)
- C42 - 10µF Lytic (see Figure B)
- R44 - 47Ω Resistor (yellow-violet-black-gold)
- U1 - IC Socket 8-pin
- U1 - LM386 Integrated Circuit (see Figure D)

- C45 - Solder the 0.1µF capacitor across pins 2 & 6 of IC U1 as shown. The capacitor prevents the IC from oscillating.



Pin 6 0.1µF Capacitor

Pin 2

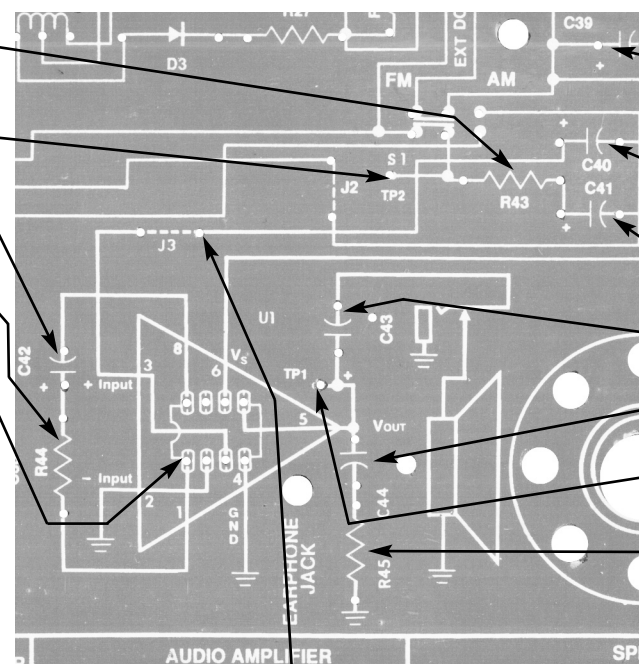

- C39 - 470µF Non-Polarized Lytic (see Figure C)
- C40 - 10µF Lytic (see Figure B)
- C41 - 10µF Lytic (see Figure B)
- C43 - 470µF Non-Polarized Lytic (see Figure C)
- C44 - .047µF Discap (473)
- TP1 - Test Point Pin (see Figure A)
- R45 - 10Ω Resistor (brown-black-black-gold)

- J3 - Jumper Wire (use a discarded lead) 

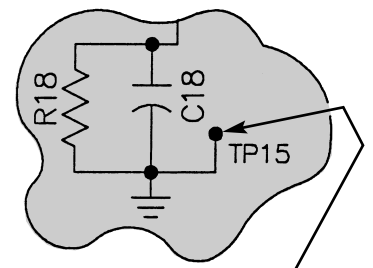

- TP-15 - Test Point Pin (see Figure A)

ASSEMBLY INSTRUCTIONS

Figure E

1 - GND
2 - Tip
3 - N.C. Tip

Foil (green) side
Jack
Nut
GND pad

Mount the jack with the nut from the foil (green) side of the PC board (terminal #1 on the GND pad of the PC board). Be sure to line up the tab with the pad on the foil side of the PC board. Solder terminal #1 to the pad of the PC board.

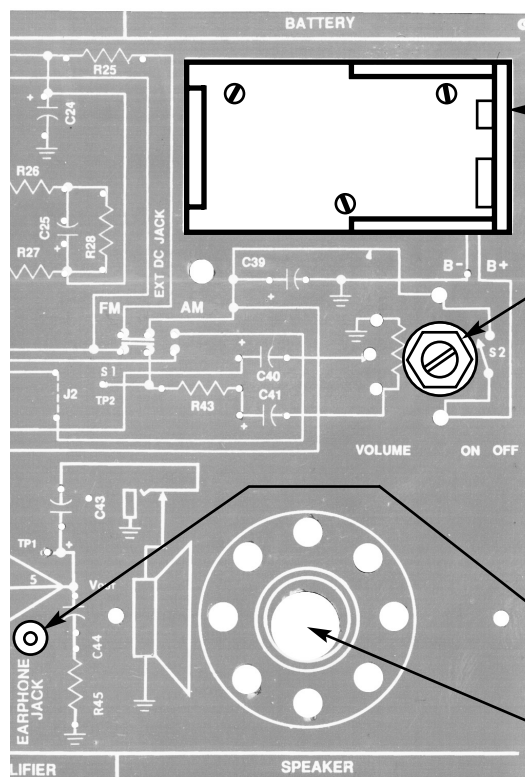

- Battery holder
 - 3 Screws M1.8 x 7.5
 - 3 Nuts M1.8
 - ** Solder and cut off excess leads. **
 - Volume/S2 (50kΩ Pot / SW) with nut & washer
 - Plastic washer
 - Knob (pot)
-
- Nut
Washer
Legend (blue) side of PC board
Cut off locating pin
Plastic washer
- ** Solder all 5 tabs to PC board **
- Earphone jack with Nut (see Figure E)
 - Speaker
 - Speaker pad
 - Wire #22AWG insulated (see Figures F & G)

Figure F

Step 1: If the speaker pad has center and outside pieces, then remove them. Peel the backing off of one side of the speaker pad and stick the pad onto the speaker.

Pad
Backing
Speaker

Step 2: Remove the other backing from the speaker pad.

Backing

Step 3: Stick the speaker onto the solder side of the PC board.

Foil side of PC Board (green side)

Figure G

Cut two 1" wires and one 1½" wire and strip ¼" of insulation off of both ends. Solder the wires in the locations shown.

1½" Wire
1" Wire
Foil side of PC Board (green side)
1" Wire

STATIC MEASUREMENTS

POWER TEST

For all measurements, connect your equipment GND to circuit GND TP15. Set your VOM (Volt-Ohm-Millimeter) to read 2 amps DC. Connect the meter to the circuit as shown in Figure 6. Make sure that the volume control is in the OFF position (turned fully counter-clockwise). While watching your VOM, turn the volume to the ON position (rotate clockwise until a “click” is heard). The VOM should indicate a very low current. Adjust your meter for a more accurate

reading if necessary. If the current is greater than 20 milliamps, immediately turn the power off. The current should be less than 10 milliamps. This is the current drawn by the battery when no input signal is present (the “idle current”). Turn OFF the power. If your circuit fails this test, check that all of the parts have been installed correctly, and check for shorts or poor solder connections.

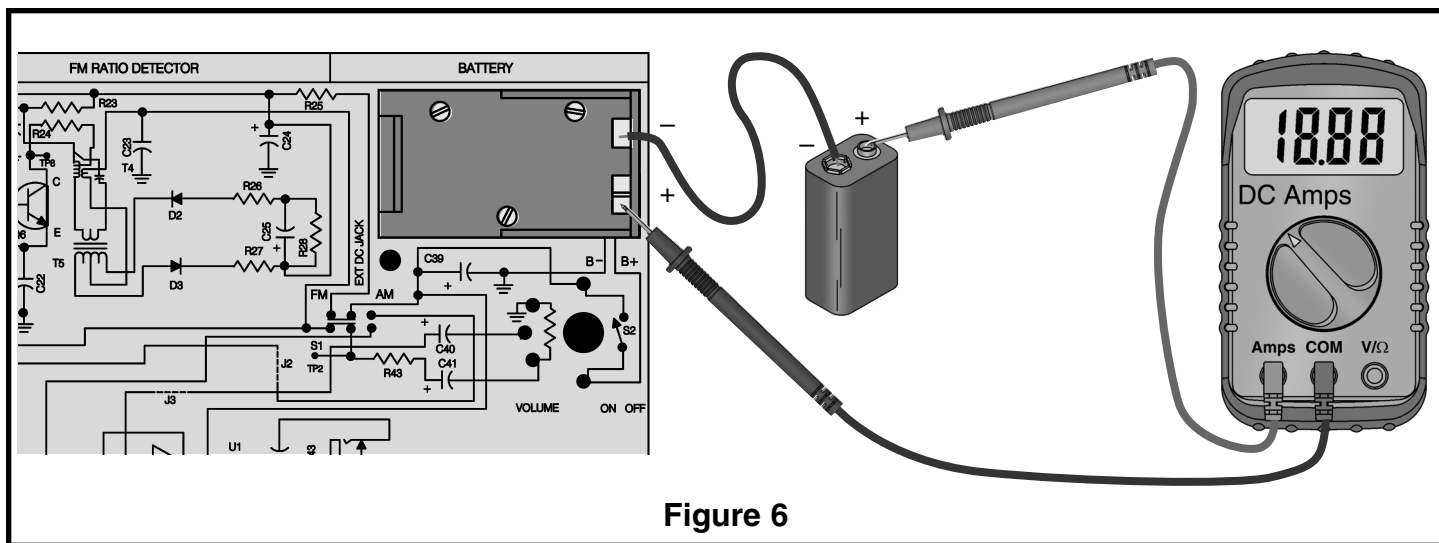

OUTPUT BIAS TEST

Put the battery into the holder.

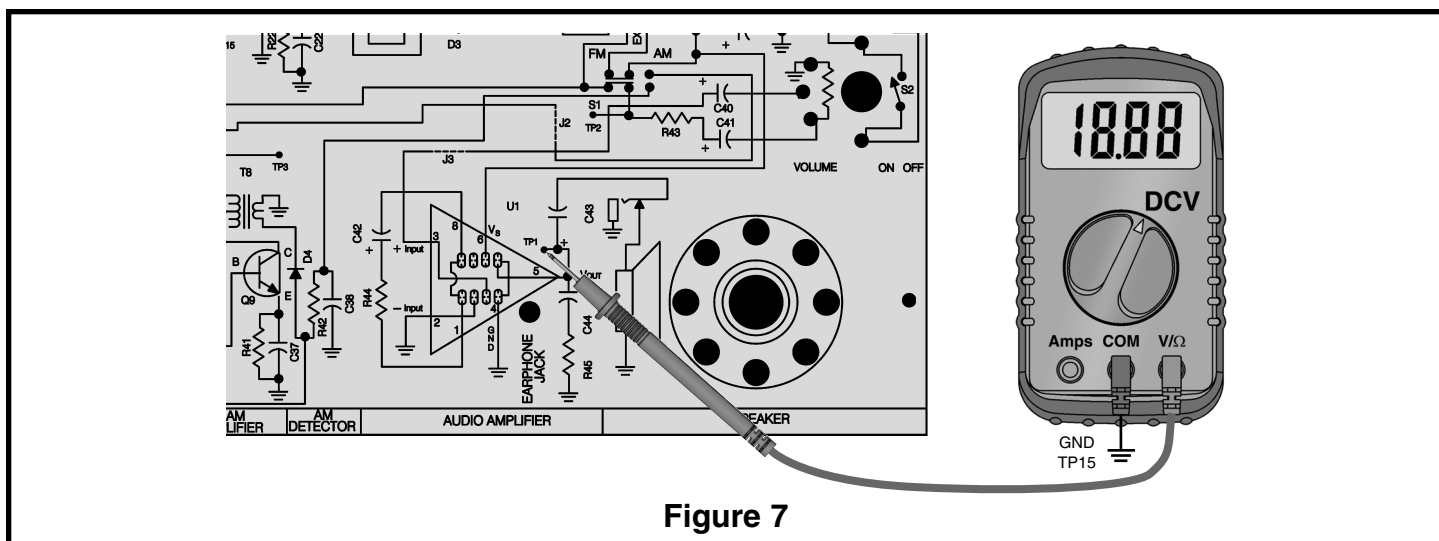

Adjust your VOM to read 9 volts and connect it as shown in Figure 7. Make sure that the battery, or a 9 volt power supply (if available), is properly connected and turn the power ON. The voltage at TP1 should be between 3 to 6 volts. If you get this reading, go on to the next test. If your circuit fails this test, turn the power OFF and check that the integrated circuit is

correctly inserted in the correct location. The notch of the IC must be in the same direction as marked on the PC board. Check that all resistor values are the correct value and not interchanged. All static tests must pass before proceeding to the Dynamic Tests or the next section.

If you do not have an audio generator, skip the following test and go directly to Section 1B.

DYNAMIC MEASUREMENTS

GAIN

Connect the VOM and audio generator to the circuit as shown in Figure 8.

Normally the AC gain is measured at a frequency of 1kHz. Your VOM however, may not be able to accurately read AC voltages at this frequency. Therefore, it is recommended that this test be performed at 400Hz. Set the audio generator at 400Hz and minimum voltage output. With the power ON, set your VOM to read an AC voltage of 1 volt at test point TP1. Increase the volume control about half way. Slowly increase the amplitude of the audio generator until your VOM reads 1 volt AC. Leave the audio generator at this setting and move the positive

lead of your VOM to the Jumper J3. Record the AC input voltage to the amplifier here:

$$V_{in} = \text{_____} \text{ volts.}$$

You may have to change scales on your VOM for the most accurate reading. Turn the power OFF. The AC voltage gain of your audio amplifier is equal to the AC output voltage divided by the AC input voltage, or $1/V_{in}$.

Calculate the gain. The gain should be 100–180.

$$\text{Gain} = \text{_____}$$

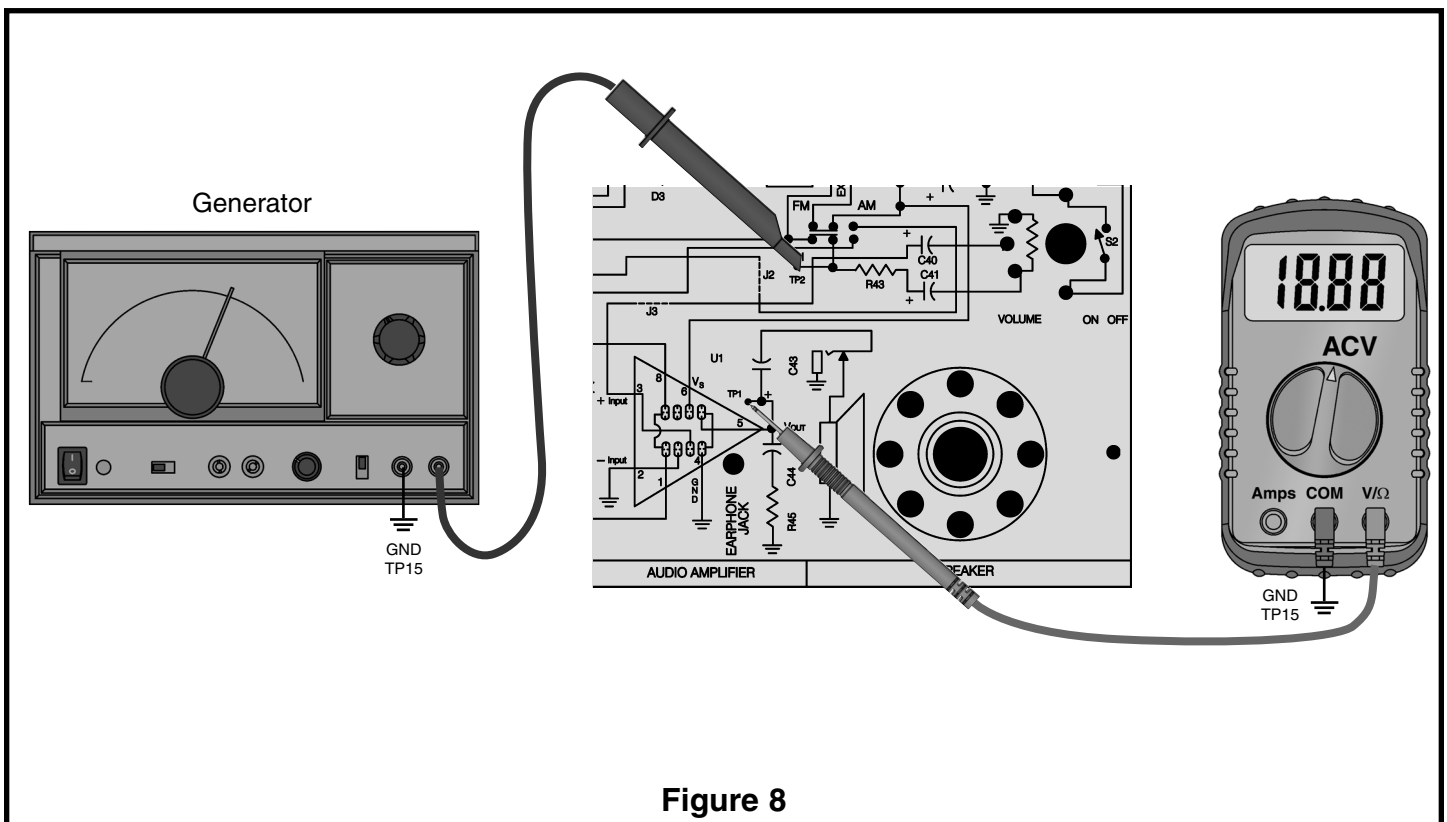

If an oscilloscope is not available, skip the following test and go directly to Section 1B.

AC BANDWIDTH

Connect the oscilloscope and audio generator to your circuit as shown in Figure 9. Set the audio generator for a frequency of 1kHz and minimum voltage output. Set the oscilloscope to read 0.5 volts per division. Turn on the power and slowly increase the volume control to a comfortable level. Increase the amplitude of the audio generator until the oscilloscope displays 2 volts peak to peak, (Vpp), at TP1. It may be necessary to adjust the volume control. Move the oscilloscope probe to jumper J3 and record the input voltage here:

$$V_{in} = \text{_____ } V_{pp}$$

(at this point, you may want to verify the AC gain).

Move the oscilloscope probe back to TP1 and slowly increase the frequency from the audio generator until the waveform on the oscilloscope drops to 0.7 of its original reading 1.4Vpp or 2.8 divisions. The frequency of the generator when the output drops to 0.7 of its original value is called the high frequency 3 decibel (dB) corner. Record this frequency here:

$$(f \text{ high 3dB}) = \text{_____ } \text{kHz.}$$

Slowly decrease the frequency of the generator until the output drops to 0.7 of its original reading, 1.4Vpp

or 2.8 divisions. This frequency is called the low frequency 3dB corner. Record your answer.

$$(f \text{ low 3dB}) = \text{_____ } \text{kHz.}$$

Calculate the AC bandwidth:

$$(f \text{ high 3dB} - f \text{ low 3dB}) = \text{_____ } \text{kHz.}$$

$$\text{AC Bandwidth} = \text{_____}$$

Your calculated answer should be greater than 30kHz.

DISTORTION

Connect the generator and oscilloscope as shown in Figure 9. Set the generator at a frequency of 1kHz, turn the power ON. Adjust the generator output and turn the volume until the peaks of the sinewave at TP1 are clipped for maximum signal as shown in Figure 10. One side of the sinewave may clip before the other depending on the DC centering at TP1. If oscillations are seen, connect a clip lead from the GND of your generator to the GND of the circuit.

Measure the maximum voltage peak to peak when clipping first occurs and record that value here:

$$V_{clip} = \text{_____ } V_{pp.}$$

Turn the power OFF.

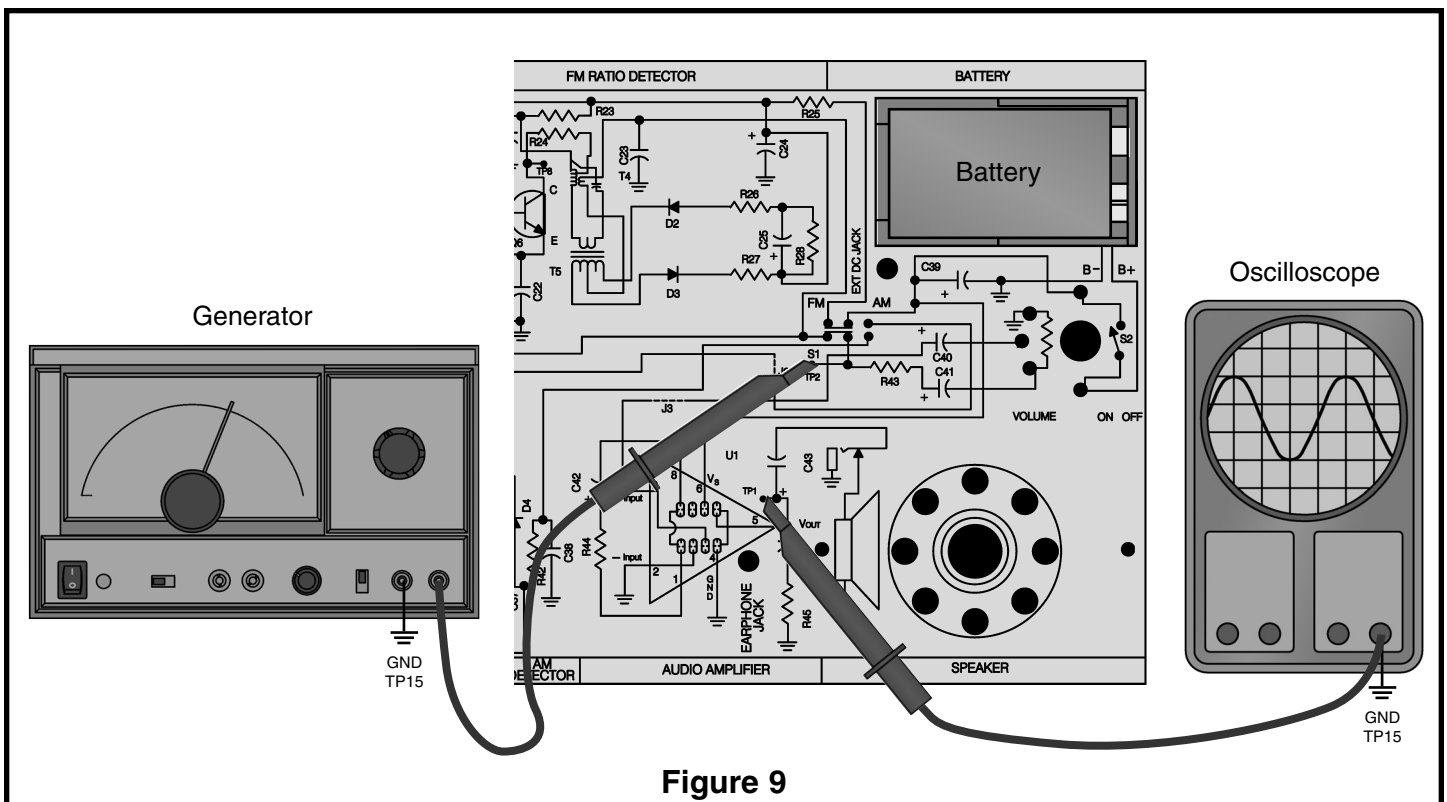

Figure 9

MAXIMUM POWER OUTPUT

The maximum power output before distortion due to “clipping” can be calculated using the voltage V_{clp} obtained in the Distortion Step as follows:

$$V_{peak} (V_p) = V_{clp}/2$$

$$V_{root\ mean\ squared} (V_{rms}) = V_p \times 0.7$$

Max power out = $(V_{rms})^2/8\ \text{ohms} = (V_{clp} \times 0.35)^2/8$
Maximum power output should be greater than 200 milliwatts.

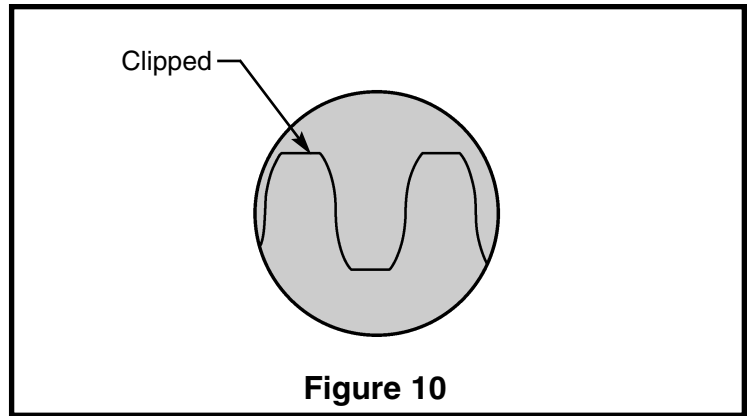

EFFICIENCY

By measuring the DC power taken from the battery at the maximum power output level, the efficiency to the audio amplifier can be calculated. Power from the battery is equal to the current taken from the battery times the voltage of the battery during maximum power output. Efficiency can then be calculated as follows: $\text{Eff} = \text{Max audio power}/\text{Battery power}$. It is best to use a power supply (if available) to prevent supply voltage from changing during these measurements.

Connect the generator, oscilloscope, power supply (or battery) and current meter as shown in Figure 11. Set your current meter to read 1 amp DC. Turn the power ON and rotate the volume control to maximum. Slowly increase the amplitude of the audio generator until the output is clipped as shown in Figure 10.

Record V_{clp} here:

$$V_{clp} = \text{_____ } V_{pp}.$$

This should be equal to V_{clp} in the Distortion Step. Record the DC current drawn from the 9 volt supply here:

$$\text{Current (I) max} = \text{_____ } \text{A}.$$

Measure the supply voltage and record the V supply here:

$$V\ \text{supply} = \text{_____ } \text{volts}.$$

Turn the power OFF.

Calculate the maximum power output as done in the Maximum Power Output Step.

Record your answers on the following page.

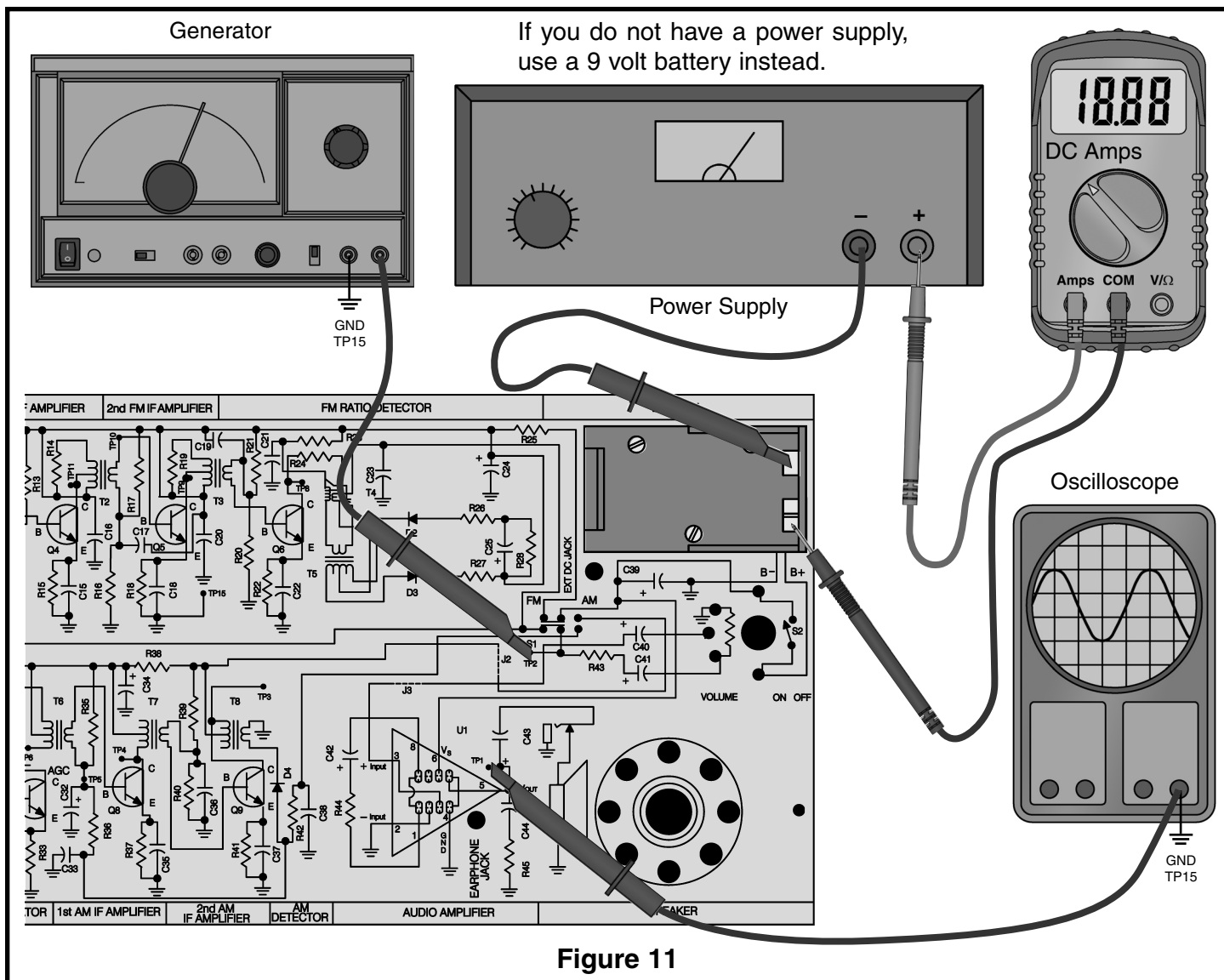

$$V_p = V_{clp}/2$$

$$V_{rms} = V_p \times 0.7$$

$$\text{Max power out} = (V_{rms})^2/8$$

$$V_p = \underline{\hspace{2cm}}$$

$$V_{rms} = \underline{\hspace{2cm}}$$

$$\text{Max power out} = \underline{\hspace{2cm}}$$

Since the battery power equals the battery voltage times the current taken from the battery; calculate the battery power:

$$\text{Battery power} = I_{max} \times V \text{ supply}$$

$$\text{Battery power} = \underline{\hspace{2cm}}$$

Since the efficiency (N) is equal to the Max power out divided by the Battery power, we can now calculate the efficiency of the audio amplifier.

$$N = \text{Max power out}/\text{Battery power}$$

$$N = \underline{\hspace{2cm}}$$

$$N \text{ in } \% = N \times 100$$

$$N = \underline{\hspace{2cm}}\%$$

Your calculated answer should be around 0.5 or 50%.

SECTION 1B

TRANSISTOR AUDIO AMPLIFIER

If you have successfully completed the IC audio amplifier, you are now ready to build the five-transistor audio amplifier. The transistor audio amplifier is built on a separate PC board and will plug into the IC socket. It will be necessary to remove the IC from its socket.

The ratio of the power delivered to the speaker and the power taken from the battery is the efficiency of the amplifier. In a Class A amplifier (transistor on over entire cycle) the maximum theoretical efficiency is 0.5 or 50%, but in a Class B amplifier (transistor on for 1/2 cycle) the maximum theoretical efficiency is 0.785 or 78.5%. Since transistor characteristics are not ideal, in a pure Class B amplifier, the transistors will introduce crossover distortion. This is due to the non-linear transfer curve near zero current or cutoff. This type distortion is shown in Figure 12.

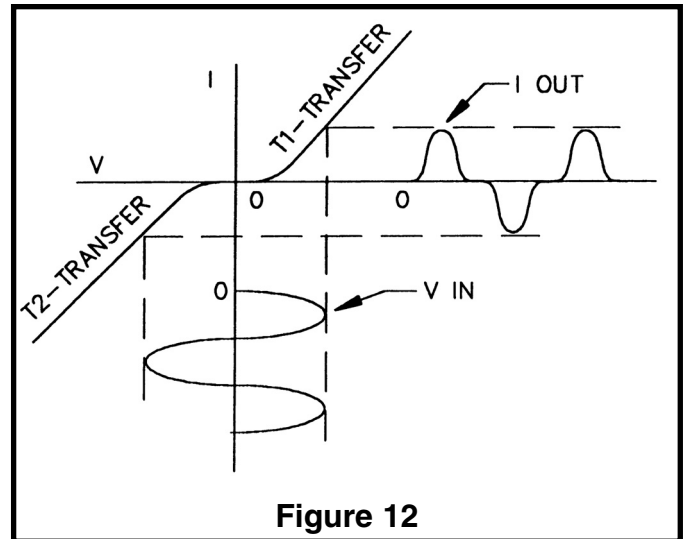
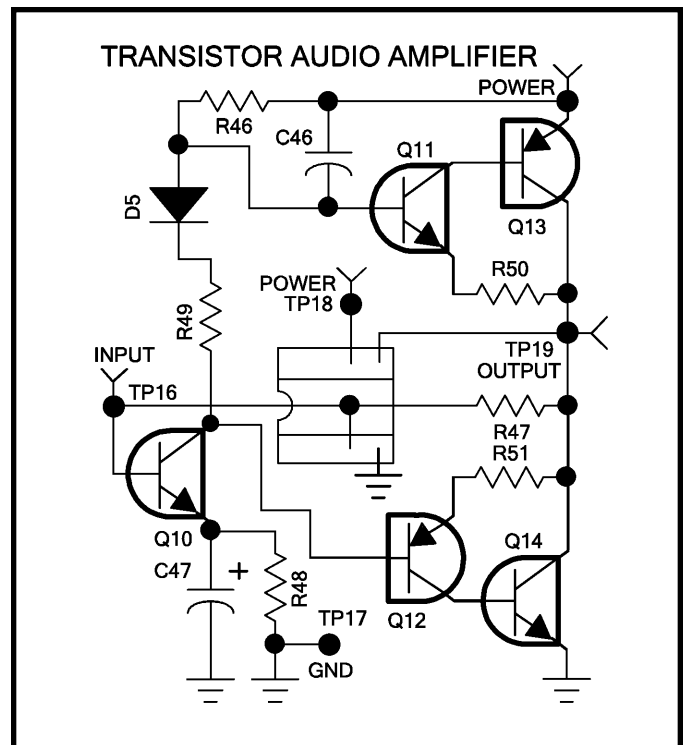

Figure 12

In order to eliminate crossover distortion and maximize efficiency, the transistors (Q11 and Q12) of the audio amplifier circuit are biased on for slightly more than 1/2 of the cycle, Class AB. In other words, the transistors are working as Class A amplifiers for very small levels of power to the speaker, but they slide toward Class B operation at larger power levels.

Transistor Q10 is a Class A amplifier that drives Q11 and Q12 through the bias string R46, D5 and R49. Q13 and Q14 are current amplifiers that amplify the current of transistors Q11 and Q12. The AC and DC gain are set by the DC current in transistor Q10 and the collector resistor R46. The AC gain of the Audio Amplifier is approximately equal to 100, while the DC gain equals approximately 50. The transistors Q13 and Q14 self bias so that the voltage at their emitters is approximately 1/2 the supply voltage. R47 provides feedback to the base of Q10 which is biased at approximately 0.7 volts. Capacitor C40 couples the audio signal from the volume control to the input of the audio amplifier. Capacitor C43 blocks the DC to the speaker, while allowing the AC to pass.



ASSEMBLY INSTRUCTIONS

Be careful to properly mount and solder all components. Diodes, transistors and electrolytic capacitors are polarized, be sure to follow the instructions carefully so that they are not mounted backwards. Check the box when you have completed each installation.

Wear safety goggles during all assembly stages in this manual. 

- TP18 - Test Point Pin
(see Figure A)
- C46 - 0.001 μ F Discap (102)
- R46 - 3.3k Ω 1/4W 5% Resistor
(orange-orange-red-gold)
- D5 - 1N4148 Diode
(see Figure H)
- R49 - 330 Ω 1/4W 5% Resistor
(orange-orange-brown-gold)
- Header (2)
(see Figure I)
- TP16 - Test Point Pin
(see Figure A)
- Q10 - 2N3904 Transistor NPN
(see Figure J)
- C47 - 47 μ F Lytic
(see Figure B)
- R48 - 47 Ω 1/4W 5% Resistor
(yellow-violet-black-gold)

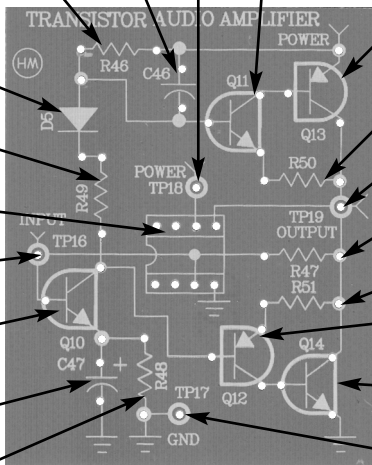

- Q11 - 2N3904 Transistor NPN
(see Figure J)
- Q13 - JE8550 Transistor PNP
(see Figure K)
- R50 - 100 Ω 1/4W 5% Resistor
(brown-black-brown-gold)
- TP19 - Test Point Pin
(see Figure A)
- R47 - 470k Ω 1/4W 5% Resistor
(yellow-violet-yellow-gold)
- R51 - 100 Ω 1/4W 5% Resistor
(brown-black-brown-gold)
- Q12 - 2N3906 Transistor PNP
(see Figure K)
- Q14 - JE8050 Transistor NPN
(see Figure J)
- TP17 - Test Point Pin
(see Figure A)

Diode

Be sure that the band is in the same direction as marked on the PC board.

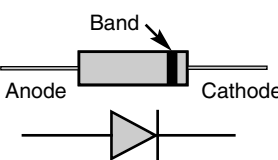

Figure H

Header

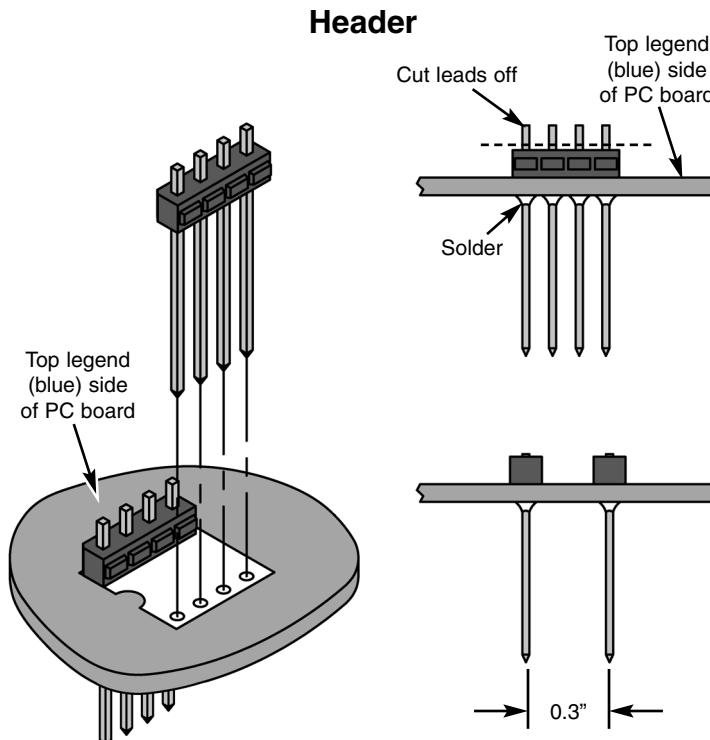
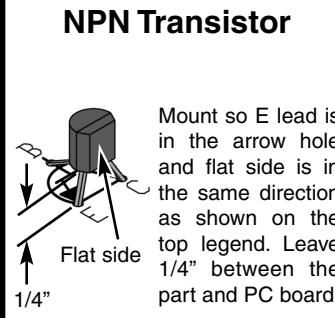

Figure I

NPN Transistor



Mount so E lead is in the arrow hole and flat side is in the same direction as shown on the top legend. Leave 1/4" between the part and PC board.

Figure J

PNP Transistor

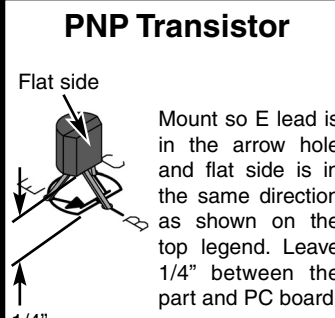

Mount so E lead is in the arrow hole and flat side is in the same direction as shown on the top legend. Leave 1/4" between the part and PC board.

Figure K

Remove IC from socket and install transistor audio amplifier PC board on the same socket.

STATIC MEASUREMENTS

POWER TEST

Set your VOM (Volt-Ohm-Millimeter) to read 2 amps DC. Connect the meter to the circuit as shown in Figure 13. Make sure that the volume control is in the OFF position (turned fully counter-clockwise). While watching you VOM, turn the volume to the ON position (rotate clockwise until a "click" is heard). The VOM should indicate a very low current. Adjust your meter for a more accurate reading if necessary. If the current

is greater than 20 milliamps, immediately turn the power OFF. The current should be less than 10 milliamps. This is the current drawn by the battery when no input signal is present (the "idle current"). Turn OFF the power. If your circuit fails this test, check that all of the parts have been installed correctly, and check for shorts or poor solder connections.

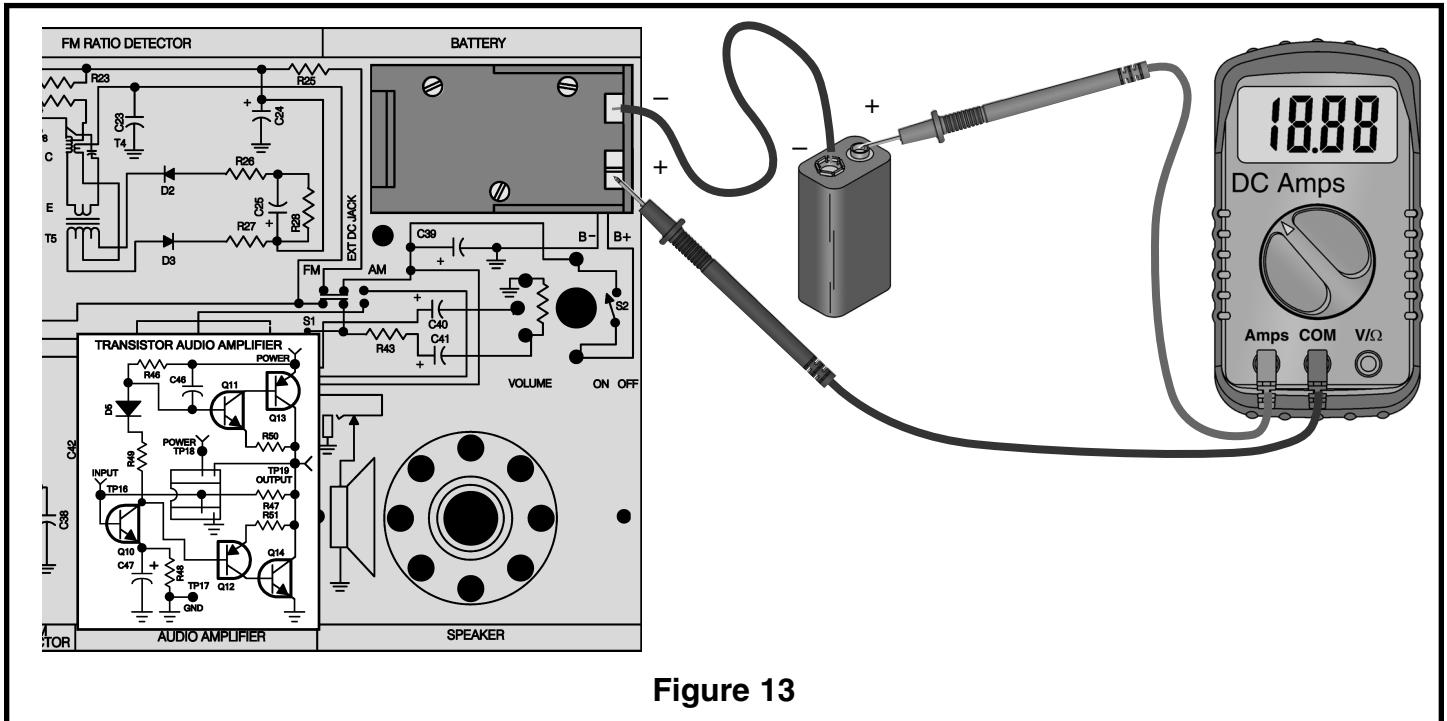

Figure 13

OUTPUT BIAS TEST

Put the battery into the holder.

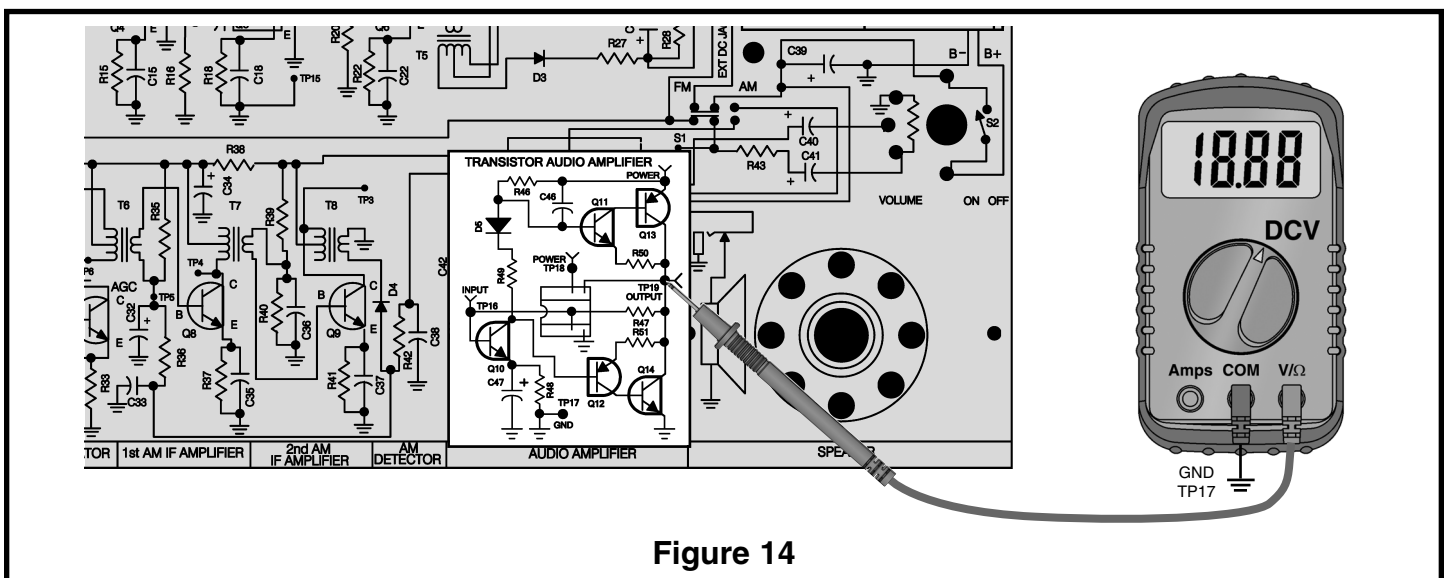

Figure 14

Adjust your VOM to read 9 volts and connect it as shown in Figure 14. Make sure that the battery, or a 9 volt power supply (if available), is properly connected and turn the power ON. The voltage at TP19 should be between 3 to 6 volts. If you get this reading, go on to the next test. If your circuit fails this test, turn the power

OFF and check that all of the transistors are correctly inserted in the correct locations. The E on the transistor indicates the emitter lead and should always be in the hole with the E next to it. Check that all resistor values are the correct value and not interchanged.

TRANSISTOR BIAS TEST

Move the positive lead of your VOM to the base of Q11. Make sure that the power is ON. The voltage should be between 0.5 and 0.8V higher than the voltage at TP19. All silicon transistors biased for conduction will have approximately 0.7V from the base to the emitter. Now move the positive lead of your VOM to the base of Q12. The voltage at this point should be between 0.5 and

0.8V lower than the voltage at TP19. This is because Q12 is a PNP type transistor. Turn the power OFF. If your circuit fails this test, check the Q11 and Q12 are properly inserted in the circuit board. All static tests must pass before proceeding to the Dynamic Tests or the next section.

DYNAMIC MEASUREMENTS

DC GAIN

The DC gain of the audio amplifier is set by the current in transistor Q10. Looking at the circuit and assuming the output bias is 1/2 of V+ or 4.5 volts, the base of Q11 will be 0.7V higher or 5.2 volts. This is because there is a negligible voltage drop across R50. This means there is a 3.8 voltage drop across R46. The current through R46 can now be calculated as $3.8/R46$ or $3.8/3.3k$ which equals 1.15 milliamps. Since D5 and R49 are used for biasing transistors Q11 and Q12, the current through Q10 can be assumed to be 1.15 milliamps. The DC gain of Q10 can be calculated as the collector

resistor, R46, divided by the emitter resistor plus the Effective Emitter Resistance. The effective emitter resistance is actually the dynamic resistance of silicon and can be calculated by the approximate equation:
 $R_j = 26 / I$ (in milliamps)

therefore, $R_j = 26 / 1.15 = 22.6$ ohms. Now the DC gain can be calculated as:

$R46 / (R48 + R_j)$ or $3300 / (47 + 22.6)$ which equals 47.4.

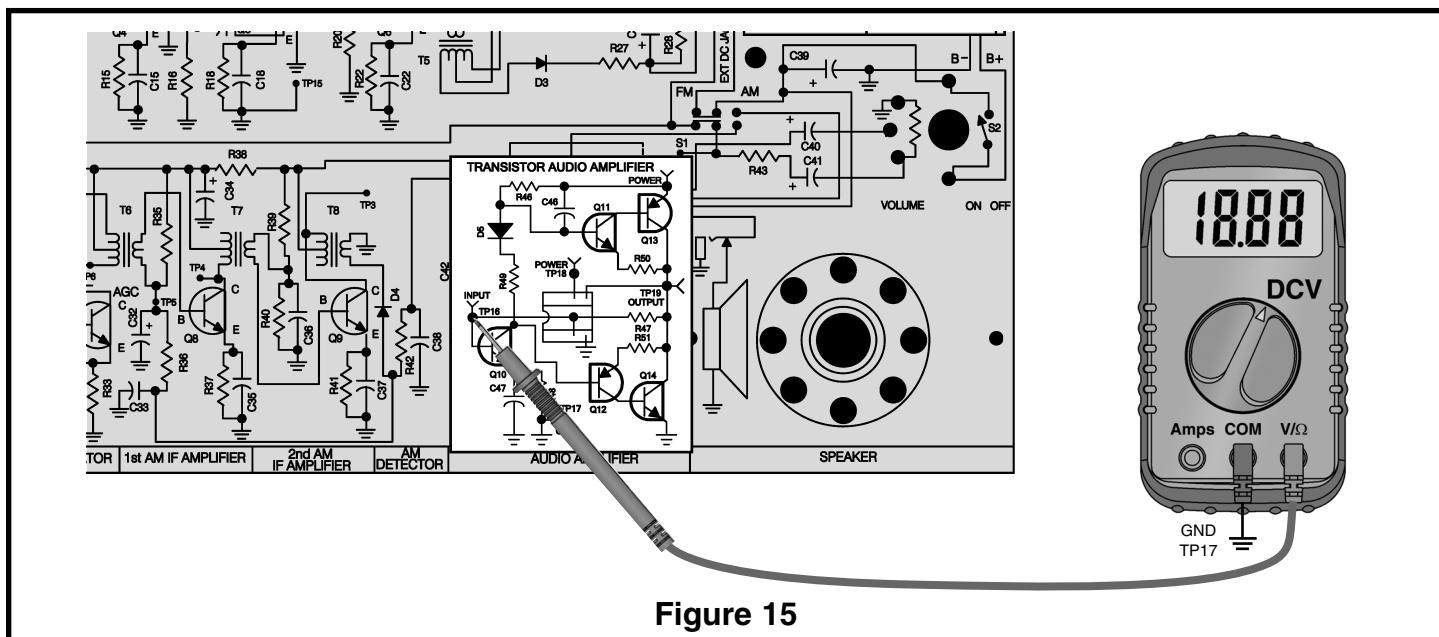

Figure 15

It is advisable to use a digital meter because of the small voltage changes in the following test. Connect your VOM to the circuit as shown in Figure 15. Set your VOM to read 1 volt DC and turn the power ON. Record the base of Q10 here:

$$V_{b1} = \text{___} \text{ volts.}$$

Now set your VOM to read 9 volts and connect the positive lead to test point TP19. Record the output bias voltage here:

$$V_o = \text{___} \text{ volts.}$$

Turn the power OFF. With a 1M ohm resistor (brown-black-green-gold), R34, connect the power supply to the circuit as shown in Figure 16.

Turn the radio ON and turn the power supply ON. Increase the supply voltage until the voltage at TP19 is equal to V_o . Now increase the voltage of the supply until the voltage at TP19 decreases by 1 volt. Move the positive lead of your VOM to the base of Q10 and record the voltage here:

$$V_{b2} = \text{___}.$$

It may be necessary to change scales of your VOM for a more accurate reading. Turn the power OFF and disconnect the power supply. Since the DC gain equals the DC change at the output divided by the DC change at the input, the DC gain of the audio can be calculated as: $1 / (V_{b2} - V_{b1})$. Your answer should be near the calculated DC gain of 47.4.

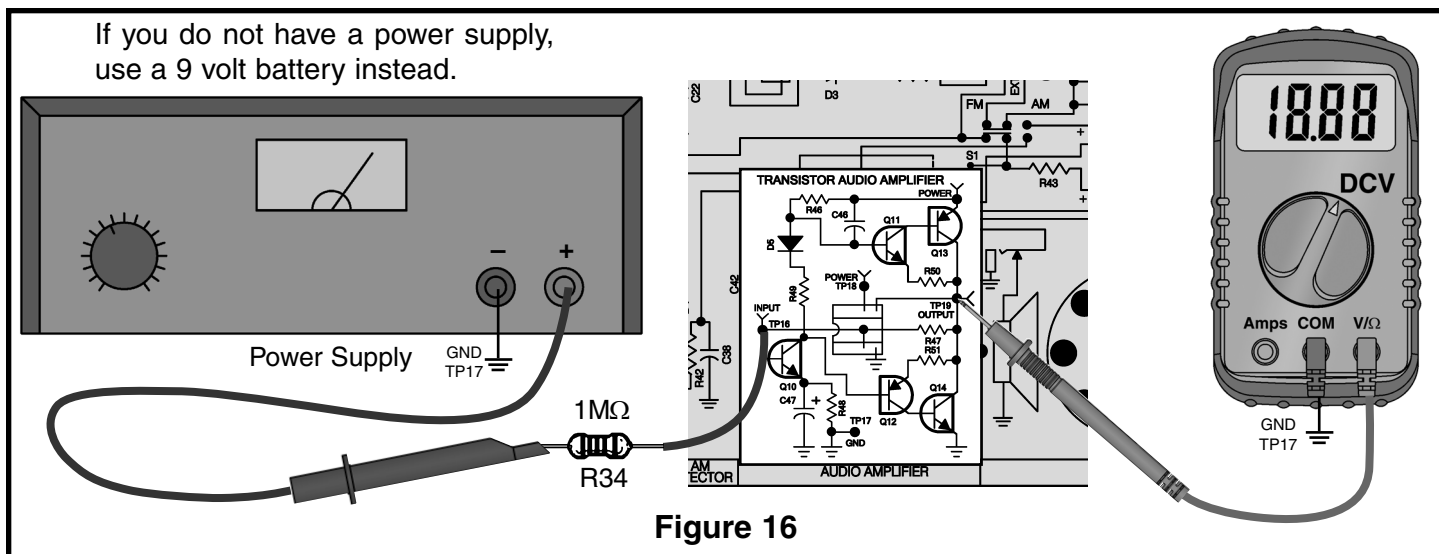

If you do not have an audio generator, skip the following test and go directly to Section 2.

AC GAIN

The AC gain can be calculated in the same manner as the DC gain except for two differences. For AC, capacitor C47 bypasses the emitter resistor R48 leaving only the effective emitter resistance, and there is a resistance seen at the output of Q13 and Q14. The AC gain of Q10 can be calculated as R_{46} / R_j or $3300 / 22.6$ which equals 146. When the input signal is positive, there will be a current flowing in Q11, which we will call $I(Q11)$. This current will then be multiplied by the Beta (β) of transistor Q13 or $\beta \times I(Q11)$. The total current at the output is equal to $I(Q11) \times (1 + \beta)$. The resistance of R50 is also seen at the output. The resistance is effectively divided by β , R_{50} / β . Assuming β of the output transistors are equal to 100 then the resistance seen at the output is equal to 1 ohm, $100 / 100$. This means that there is a voltage divider between the output and the 8 ohm speaker. The signal is now divided down so that the output is equal to the AC (gain of Q10) $\times (8 / (1+8))$, or $146 \times (8 / 9)$ which equals 130. This is also true when the input signal is negative. The

only difference is that Q12 and Q14 are now conducting. Connect the VOM and audio generator to the circuit as shown in Figure 17.

Normally the AC gain is measured at a frequency of 1kHz. Your VOM, however may not be able to accurately read AC voltages at this frequency. Therefore, it is recommended that this test be performed at 400Hz. Set the audio generator at 400Hz and minimum voltage output. With the power ON, set your VOM to read an AC voltage of 1 volt at test point TP19. Increase the volume control about half way. Slowly increase the amplitude of the audio generator until your VOM reads 1 volt AC. Leave the audio generator at this setting and move the positive lead of your VOM to TP16. Record the AC input voltage to the amplifier here:

$$V_{in} = \text{___} \text{ volts.}$$

You may have to change scales on your VOM for the most accurate reading. Turn the power OFF. The AC voltage gain of your audio amplifier is equal to the AC

output voltage divided by the AC input voltage, or $1/V_{in}$. The gain should approximately equal the calculated gain.

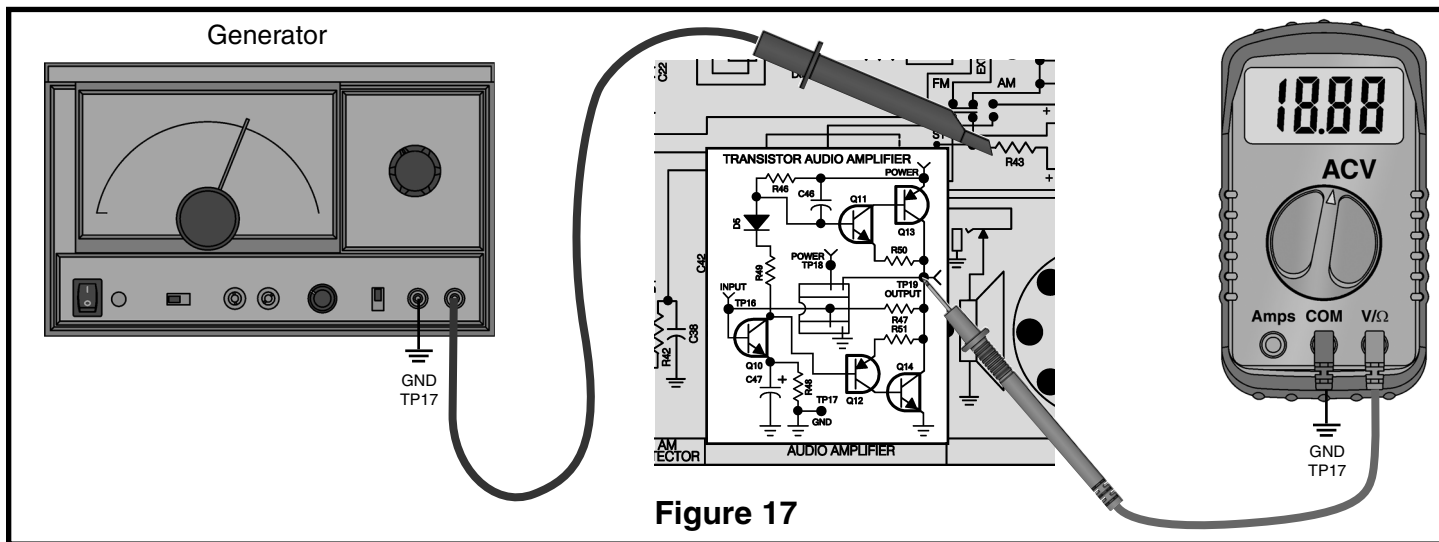

Figure 17

If an oscilloscope is not available, skip the following test and go directly to Section 2.

AC BANDWIDTH

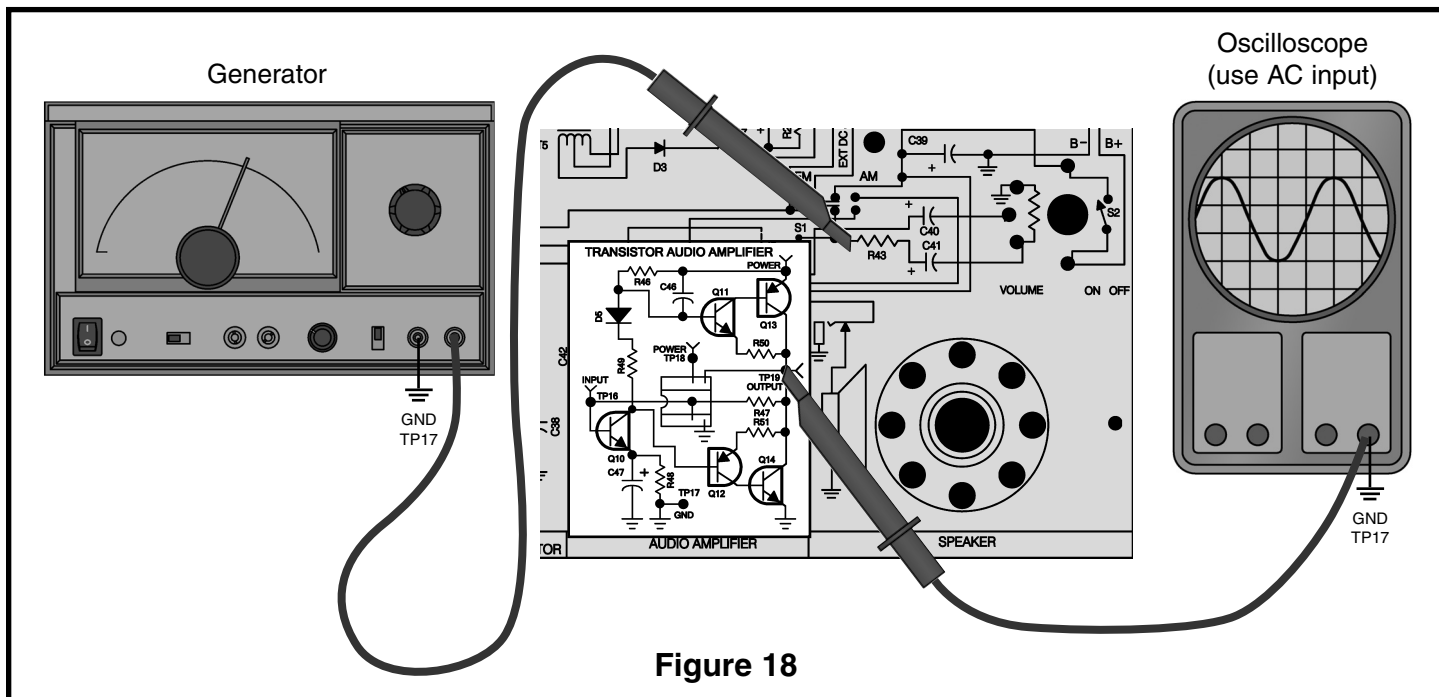

Figure 18

Connect the oscilloscope and audio generator to your circuit as shown in Figure 18.

Set the audio generator for a frequency of 1kHz and minimum voltage output. Set the oscilloscope to read 0.5 volts per division. Turn on the power and slowly increase the volume control to a comfortable level. Increase the amplitude of the audio generator until the oscilloscope displays 2 volts peak to peak, (Vpp), at TP19. It may be necessary to adjust the volume control. Move the oscilloscope probe to the base of Q10 (TP16) and record the input voltage here:

$V_{in} = \text{_____ Vpp}$

(at this point, you may want to verify the AC gain).

Move the oscilloscope probe back to TP19 and slowly increase the frequency from the audio generator until the waveform on the oscilloscope drops to 0.7 of its original reading (1.4Vpp or 2.8 divisions). The frequency of the generator, when the output drops to 0.7 of its original value, is called the high frequency 3 decibel (dB) corner. Record this frequency here:

(f high 3dB) = _____ kHz.

Slowly decrease the frequency of the generator until the output drops to 0.7 of its original reading, 1.4Vpp or 2.8 divisions. This frequency is called the low frequency 3dB corner - the low frequency 3dB corner or (f high 3dB) - (f low 3dB). Your calculated answer should be greater than 30kHz.

DISTORTION

Connect the generator and oscilloscope as shown in Figure 18. Set the generator at a frequency of 1kHz, turn the power ON and turn the volume to maximum. Adjust the generator output until the peaks of the sinewave at TP19 are clipped as shown in Figure 19A. One side of the sinewave may clip before the other depending on the DC centering at TP19. If oscillations are seen, connect a clip lead from the GND of your generator to the GND of the circuit.

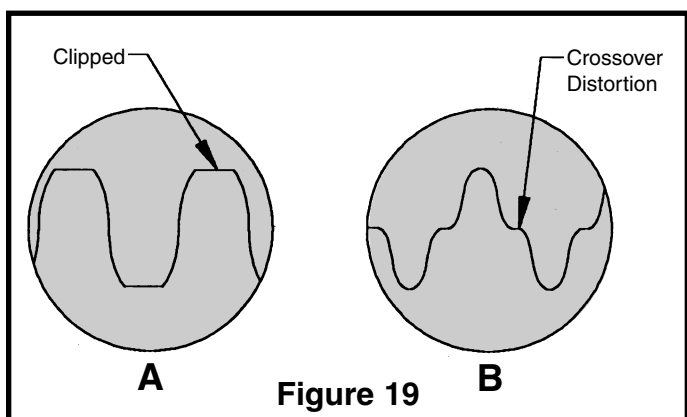

Figure 19

Measure the maximum voltage peak to peak when clipping first occurs and record that value here:

$$V_{clip} = \text{_____ } V_{pp}$$

Using a wire short out diode D5 and resistor R49 as shown in Figure 20. The waveform should resemble Figure 19B. The “flat spots” near the center of each sinewave demonstrate what is called crossover distortion. Most of this distortion should disappear when you remove the shorting lead. Turn the power OFF.

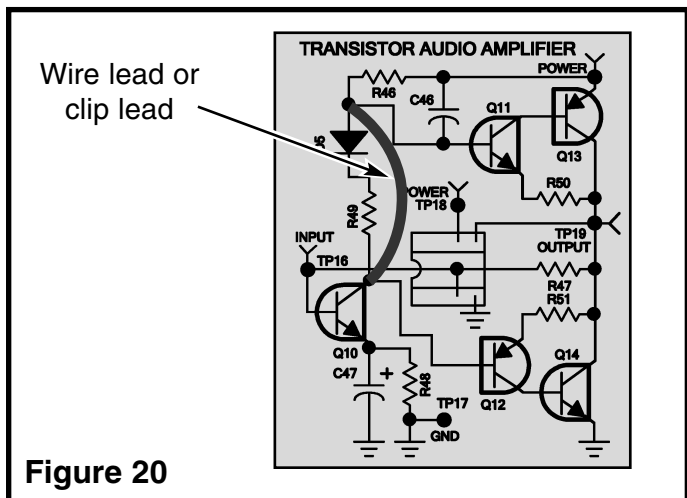

Figure 20

MAXIMUM POWER OUTPUT

The maximum power output before distortion due to “clipping” can be calculated using the voltage V_{clip} obtained in step 4 as follows:

$$V_{peak} (V_p) = V_{clip}/2$$

$$V_{root\ mean\ squared} (V_{rms}) = V_p \times 0.7$$

Max power out = $(V_{rms})^2/8\ \text{ohms} = (V_{clip} \times 0.35)^2/8$
 Maximum power output should be greater than 350 milliwatts.

EFFICIENCY

By measuring the DC power taken from the battery at the maximum power output level, the efficiency to the audio amplifier can be calculated. Power from the battery is equal to the current taken from the battery times the voltage of the battery during maximum power output. Efficiency can then be calculated as follows: $\text{Eff} = \text{Max audio power}/\text{Battery power}$. It is best to use a power supply (if available) to prevent supply voltage from changing during these measurements. Connect the generator, oscilloscope and current meter as shown in Figure 21. Set your current meter to read 1 amp DC. Turn the power ON and rotate the volume control to maximum. Slowly increase the amplitude of the audio generator until the output is clipped as shown in Figure 19A. Record V_{clip} here:

$$V_{clip} = \text{_____ } V_{pp}$$

This should be equal to V_{clip} in step 4. Record the DC current drawn from the 9 volt supply here:

$$\text{Current (I) max} = \text{_____ } \text{Amps}$$

Measure the supply voltage and record the V supply here:

$$V\ \text{supply} = \text{_____ } \text{volts}$$

Turn the power OFF. Calculate the maximum power output as done in the Maximum Power Output Step.

Record your answers on the following page.

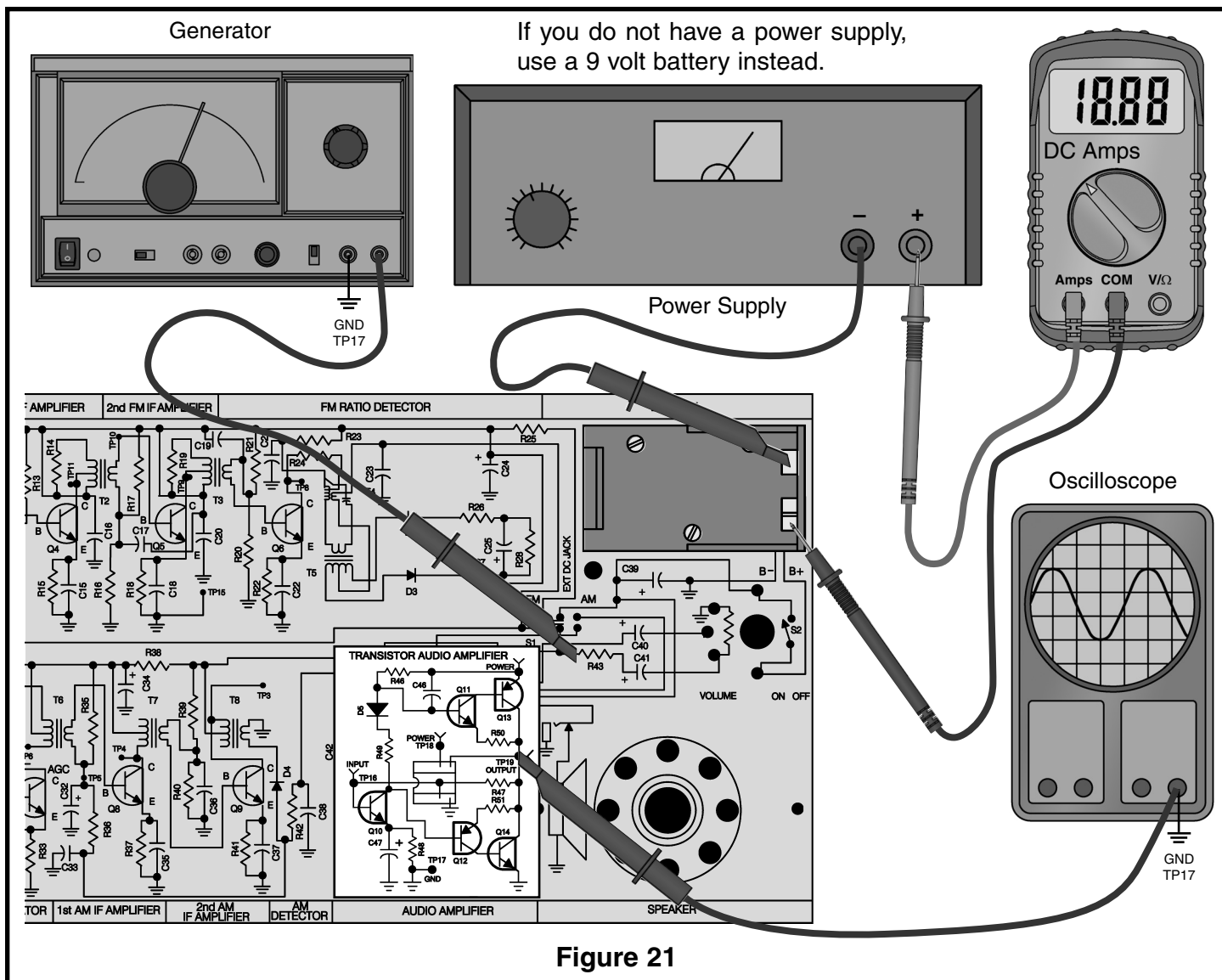

Figure 21

$$V_p = V_{clp}/2$$

$$V_p = \underline{\hspace{2cm}}$$

$$V_{rms} = V_p \times 0.7$$

$$V_{rms} = \underline{\hspace{2cm}}$$

$$\text{Max power out} = (V_{rms})^2/8$$

$$\text{Max power out} = \underline{\hspace{2cm}}$$

Since the battery power equals the battery voltage times the current taken from the battery; calculate the battery power:

$$\text{Battery power} = I_{max} \times V \text{ supply}$$

$$\text{Battery power} = \underline{\hspace{2cm}}$$

Since the efficiency (N) is equal to the Max power out divided by the Battery power, we can now calculate the efficiency of the audio amplifier.

$$N = \text{Max power out}/\text{Battery power}$$

$$N = \underline{\hspace{2cm}}$$

$$N \text{ in } \% = N \times 100$$

$$N = \underline{\hspace{2cm}}\%$$

Your calculated answer should be around 0.5 or 50%.

SECTION 2

AM DETECTOR AND AGC STAGE

The purpose of the detector is to change the amplitude modulated IF signal back to an audio signal. This is accomplished by a process called detection or demodulation. First, the amplitude modulated IF signal is applied to a diode in such a way as to leave only the negative portion of that signal (see Figure 22). The diode acts like an electronic check valve that only lets current pass in the same direction as the arrow (in the diode symbol) points. When the diode is in conduction (On Condition), it will force the capacitors C33 and C38 to

charge to approximately the same voltage as the negative peak of the IF signal. After conduction stops in the diode (Off Condition), the capacitors will discharge through resistors R36 and R42. The discharge time constant must be small enough to follow the audio signal or high frequency audio distortion will occur. The discharge time constant must be large enough, however, to remove the intermediate frequency (455kHz) and leave only the audio as shown in Figure 22.

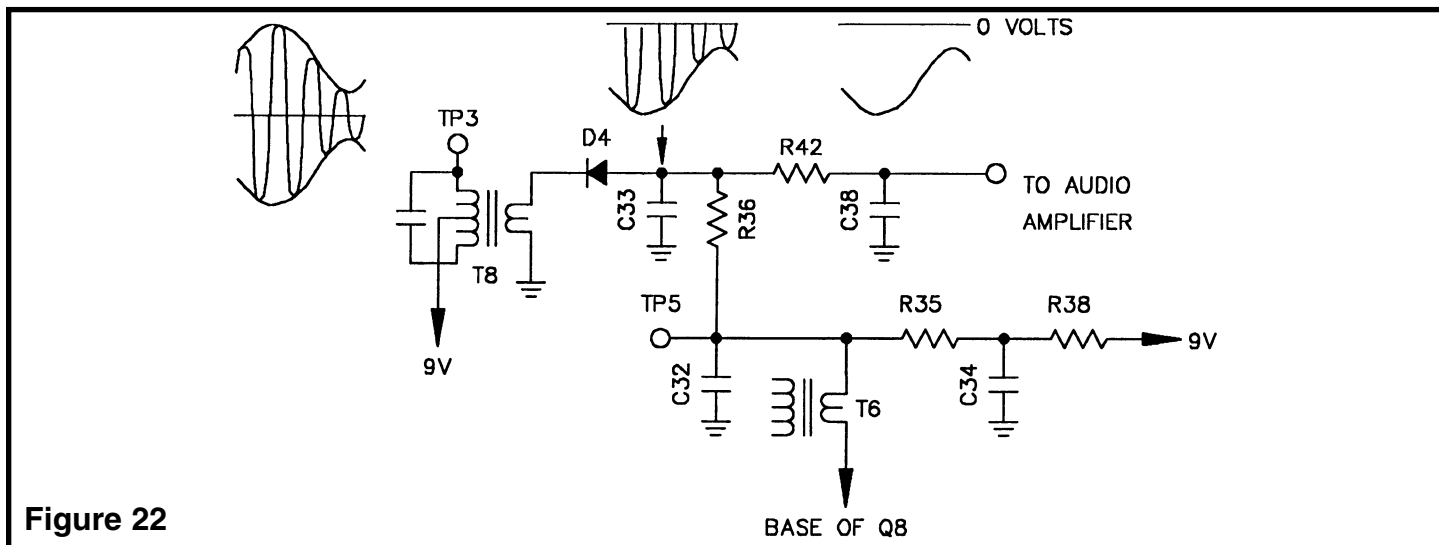

Figure 22

The purpose of the automatic gain control (AGC) circuit is to maintain a constant level at the detector, regardless of the strength of the incoming signal. Without AGC, the volume control would have to be adjusted for each station and even moderately strong stations would clip in the final IF amplifier causing audio distortion. AGC is accomplished by adjusting the DC bias of the first IF amplifier to lower its gain as the signal strength increases. Figure 22 shows that the audio at the top of the volume control is actually “riding” on a negative DC voltage when

strong signals are encountered. This negative DC component corresponds to the strength of the incoming signal. The larger the signal, the more negative the component. At test point five (TP5), the audio is removed by a low pass filter, R36 and C32, leaving only the DC component. Resistor R35 is used to shift the voltage at TP5 high enough to bias the base of transistor Q8 to the full gain position when no signal is present. Resistors R35 and R36 also forward bias diode D4 just enough to minimize “On Condition” threshold voltage.

Remove the transistor audio amplifier PC board and install the integrated circuit (IC) into the socket.

ASSEMBLY INSTRUCTIONS

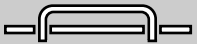
- Switch
 - J2 - Jumper Wire
(use a discarded lead)
- 

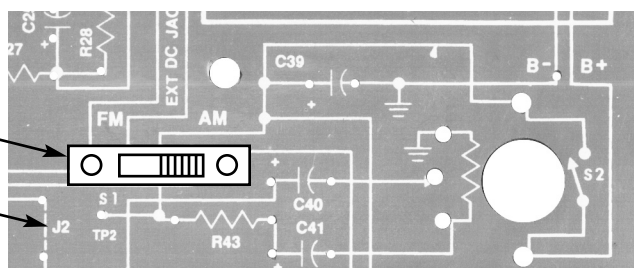

ASSEMBLY INSTRUCTIONS

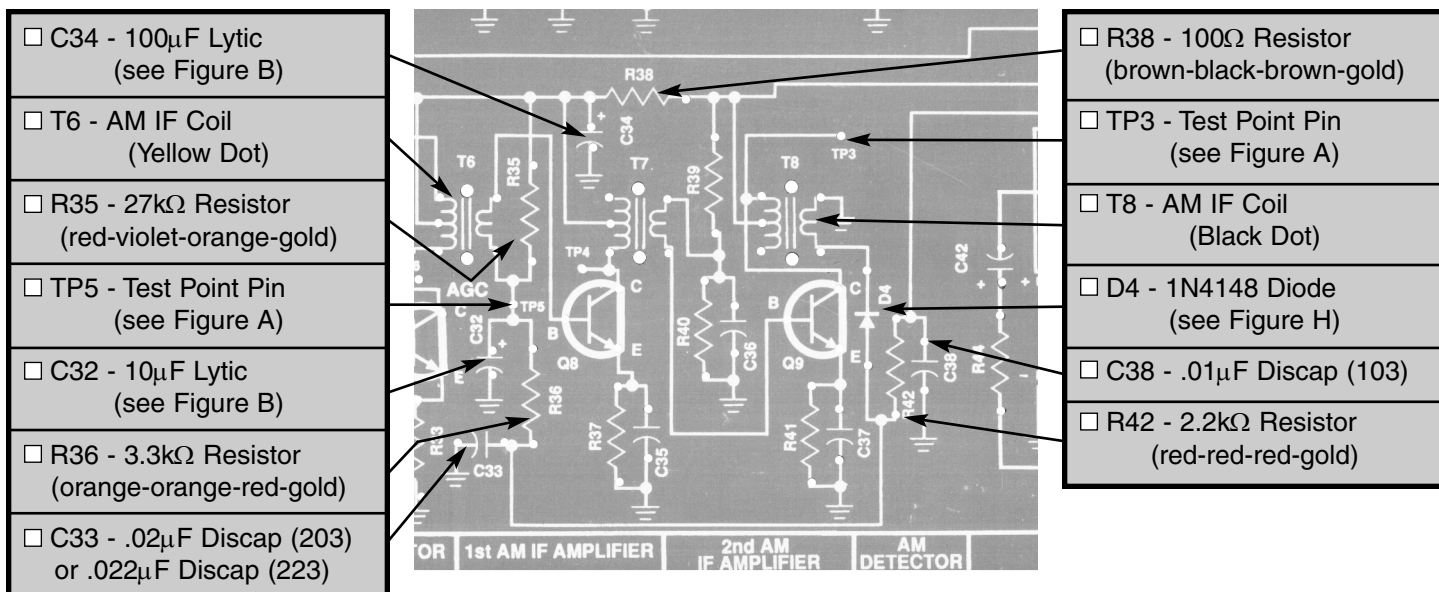

STATIC MEASUREMENTS

AGC ZERO SIGNAL BIAS

With the power turned OFF, connect your VOM to TP5 as shown in Figure 23. Make sure that the AM/FM switch is in the AM position.

Check that the VOM is adjusted to read 9 volts DC and turn the power ON. The voltmeter should read approximately 1.5 volts DC. If your reading varies by more than 0.5 volts from this value, turn the power OFF and check the polarity of D4. Also check R36 and R35 and check that transformer T6 is properly installed.

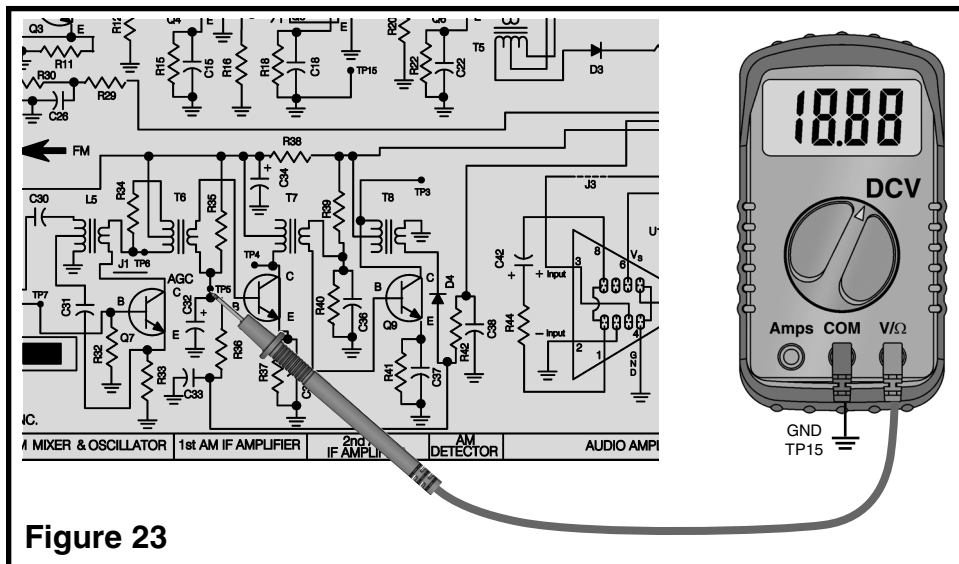

T8 TEST

With the power turned OFF, connect the positive lead of the VOM to TP3 and the negative lead to ground pin TP15. Make sure that the VOM is set to read 9 volts DC and turn the power ON. The voltage on the

VOM should be the same as your battery voltage or power supply voltage. If not, turn the power OFF and check that T8 is properly installed. Turn the power OFF.

If you do not have an RF generator, skip to Section 3.

DYNAMIC MEASUREMENTS

AM DETECTOR AND AGC TEST

Connect your VOM and RF generator as shown in Figure 24.

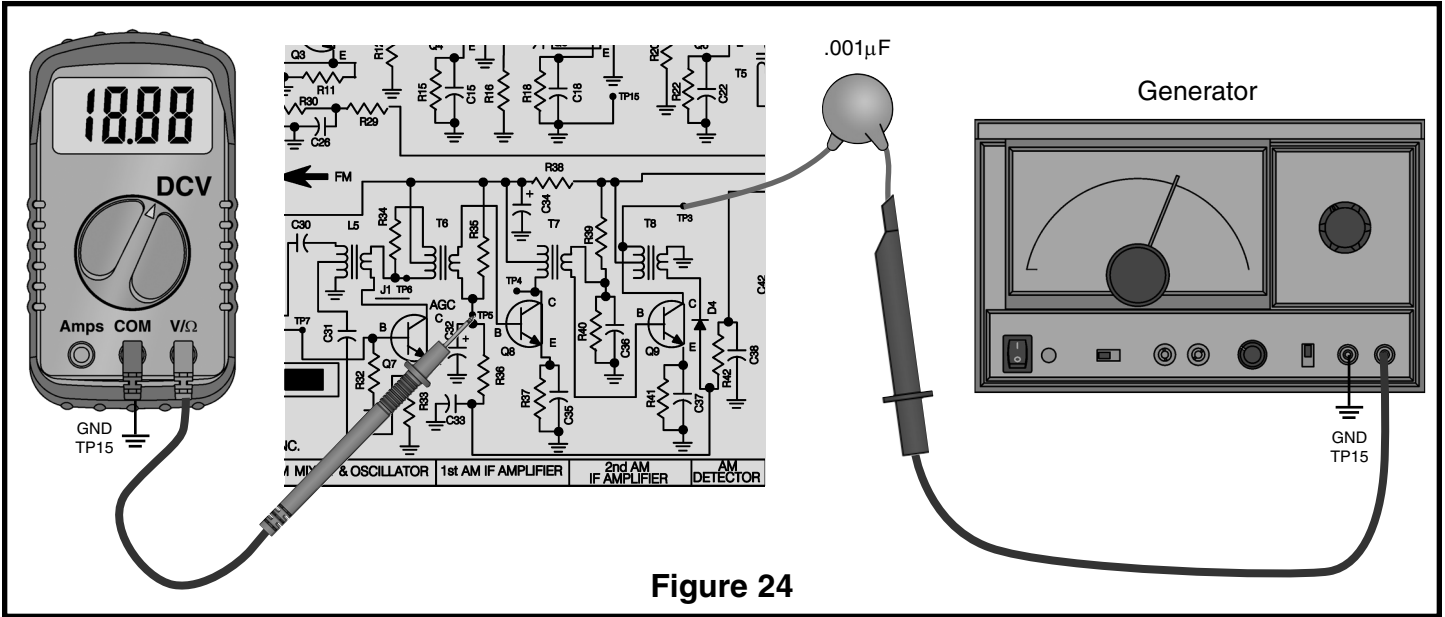

Figure 24

Set the VOM to accurately read 2 volts DC and set the output of the RF generator for 455kHz, no modulation, and minimum voltage output. Turn the power ON and slowly increase the amplitude of the

generator until the voltage at TP5 just starts to drop. This point is called the AGC threshold with no IF gain. Make a note of the amplitude setting on the RF generator here: _____.

If your RF generator does not have amplitude modulation and you do not have an oscilloscope, skip to Section 3.

SYSTEM CHECK

Connect your equipment as shown in Figure 25.

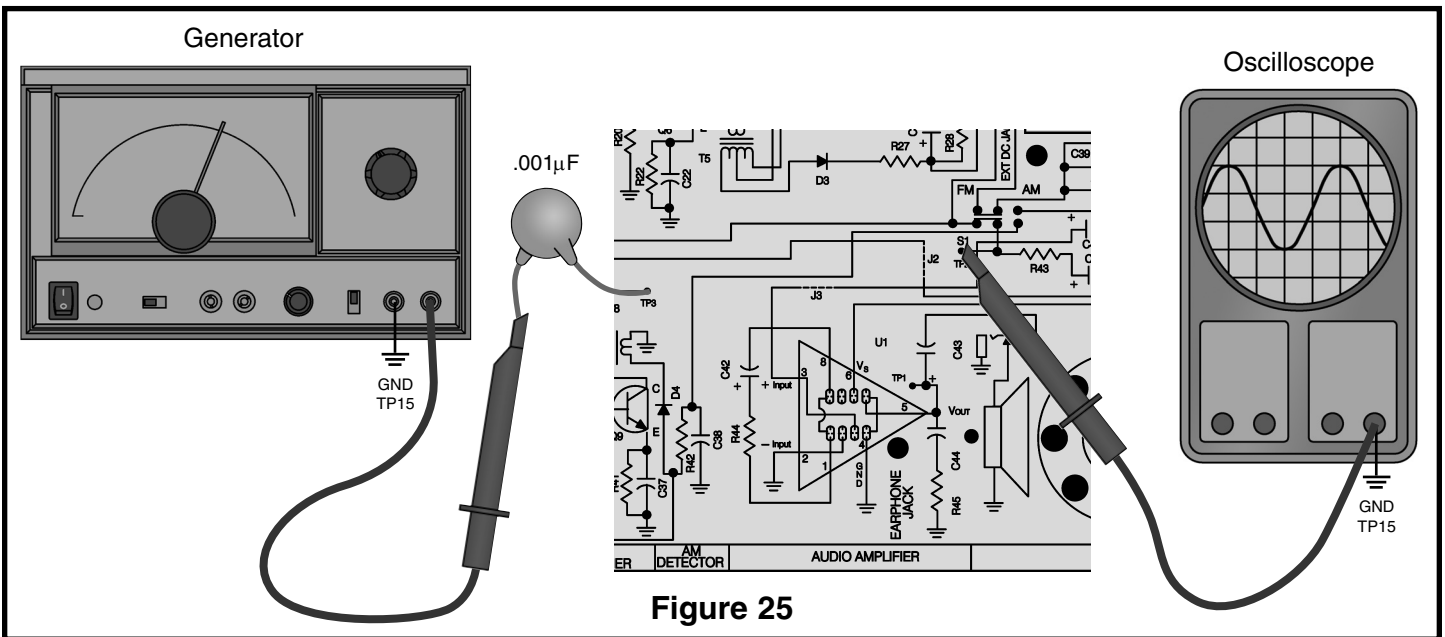

Figure 25

Set the RF generator at 455kHz, 1kHz at 80% modulation and minimum voltage output. Turn the power ON and set the volume control at maximum. Slowly adjust the amplitude of the RF generator

output until you hear the 1kHz tone on the speaker. If this test fails, turn the power OFF and check R42 and D4. Turn the power OFF.

AM DETECTOR BANDWIDTH TEST

Connect your test equipment as shown in Figure 25. Set the generator at 455kHz with 80% modulation at a modulation frequency of 1kHz. Set the oscilloscope to read 0.1 volts per division. Turn the power ON and set the volume at the minimum. Increase the amplitude of the generator until the signal on the oscilloscope is 4 divisions peak to peak. Check the signal to make sure that it is free of distortion. Leave the frequency of the generator at 455kHz, but

increase the modulation frequency until the output drops to 0.28Vpp. Record the modulation frequency on the generator here:

This frequency should be greater than 5kHz. Turn the power OFF.

SECTION 3

SECOND AM IF AMPLIFIER

The purpose of the second IF amplifier is to increase the amplitude of the intermediate frequency (IF) and at the same time provide SELECTIVITY. Selectivity is the ability to "pick out" one radio station while rejecting all others. The second IF transformer (T8) acts as a bandpass filter with a 3dB bandwidth of approximately 6kHz. The amplitude versus frequency response of the second IF amplifier is shown in Figure 26.

Both IF amplifiers are tuned to a frequency of 455kHz and only need to be aligned once when the radio is assembled. These amplifiers provide the majority of the gain and selectivity needed to separate the radio stations.

The gain at 455kHz in the second IF amplifier is fixed by the AC impedance of the primary side of transformer T8, and the DC current in Q9. The current in Q9 is set by resistors R39, R40 and R41. Both C36 and C37 bypass the 455kHz signal to ground, making Q9 a common emitter amplifier. The signal is coupled from the first IF amplifier to the second IF amplifier through transformer T7. The IF transformers not only supply coupling and selectivity, they also provide an impedance match between the collector of one stage and the base of the next stage. This match allows maximum power to transfer from one stage to the next.

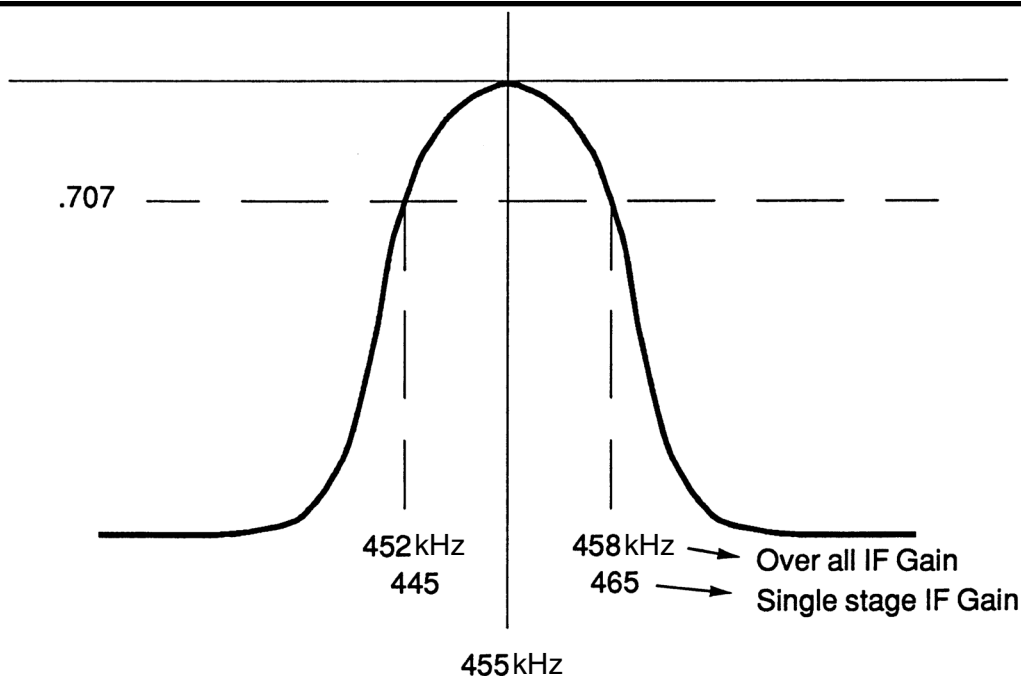
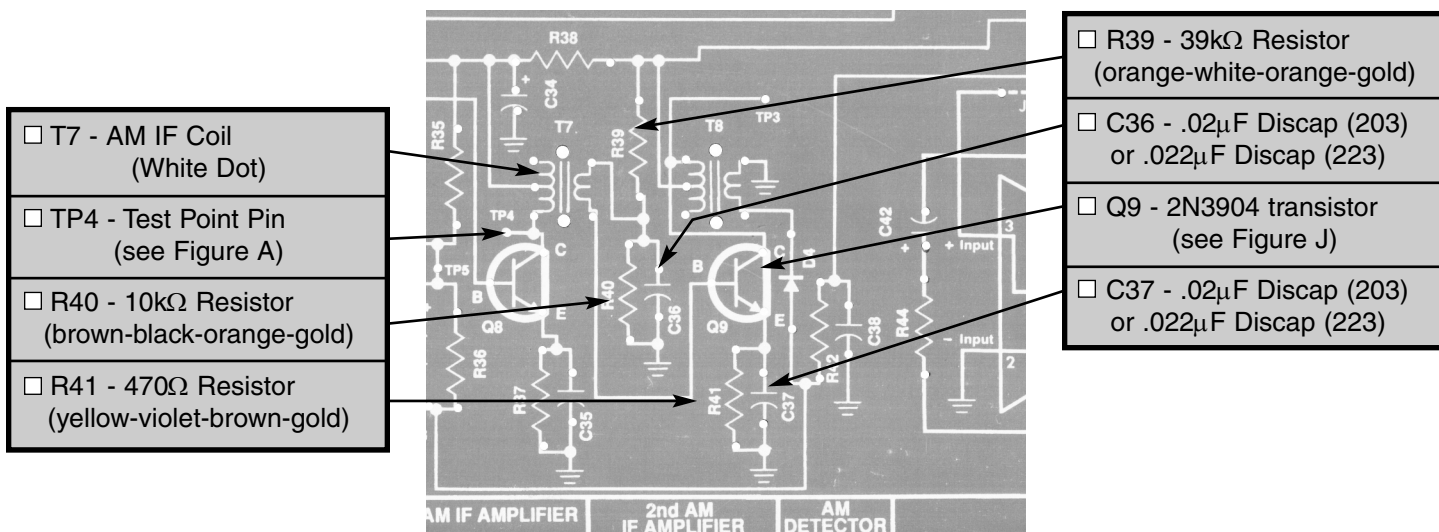

Figure 26

ASSEMBLY INSTRUCTIONS



STATIC MEASUREMENTS

Q9 BIAS

Connect your VOM as shown in Figure 27. Set the VOM to read 9 volts DC and turn the power ON. The voltage at the emitter of Q9 should be approximately

1 volt. If your reading is different by more than 0.5 volts, turn the power OFF and check components R39, R40, R41 and Q9.

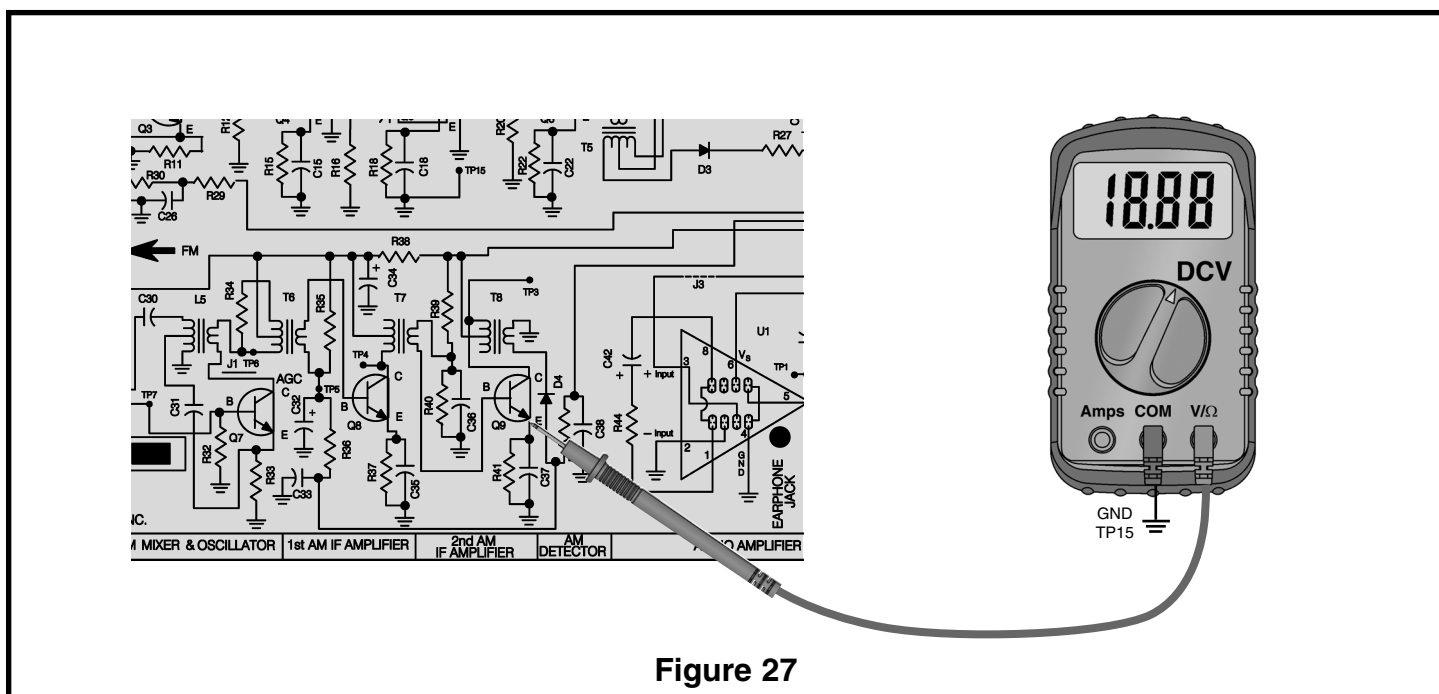

Figure 27

If you do not have an RF generator and oscilloscope, skip to Section 4.

DYNAMIC MEASUREMENTS

AC GAIN

Connect your test equipment as shown in Figure 28.

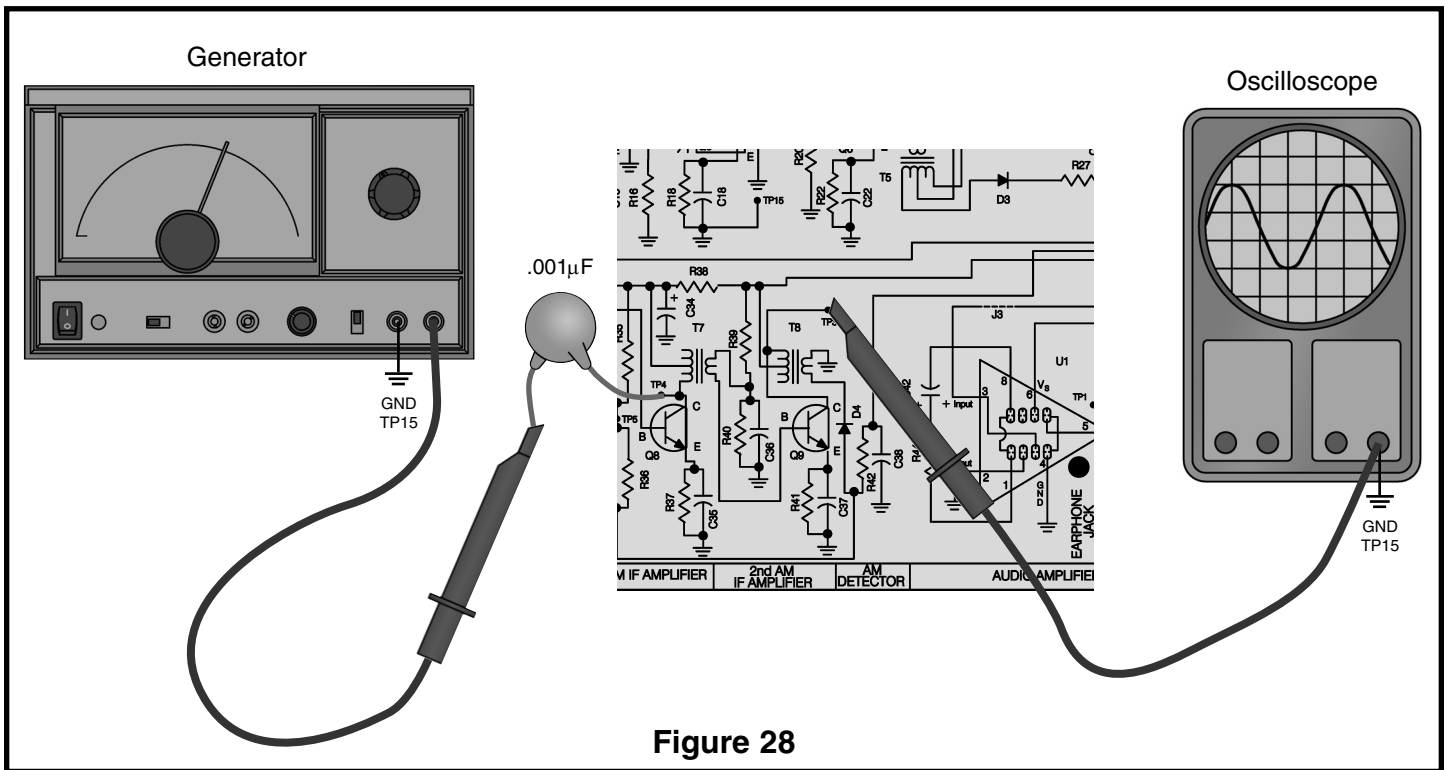

Figure 28

Set the generator at 455kHz, no modulation and minimum voltage output. Set the oscilloscope at 1 volt per division. The scope probe must have an input capacitance of 12pF or less or it will detune T8. Turn the power ON and slowly increase the amplitude of the generator until 4 volts peak to peak are seen on the scope. With an alignment tool or screwdriver, tune T8 for a peak on the scope while readjusting the generator's amplitude to maintain 4Vpp at the oscilloscope. After T8 is aligned, move the scope probe to the base of Q9 and record the peak to peak amplitude of the signal here:

$$V_b = \text{_____} V_{pp}$$

Turn the power OFF. The AC gain of the second IF amplifier at 455kHz is equal to $4/V_b$ and should be greater than 100. If your value is less than 50 check components R39, R40, R41, C36 and C37. Also make sure that Q9 is properly installed. Turn the power OFF.

BANDWIDTH

Reconnect your test equipment as shown in Figure 28. Turn the power ON and adjust the generator for 4 volts peak to peak at TP3. Realign T8, if necessary, for maximum output while adjusting the output of the generator to maintain 4Vpp at TP3. Slowly decrease the frequency of the RF generator until the signal at TP3 drops to 0.707 of its original value or 2.8Vpp. Record the frequency of the RF generator here:

$$F_l = \text{_____} \text{ kHz.}$$

Now increase the frequency of the generator past the peak to a point where the signal drops to 0.707 of its peak value. Record that frequency here:

$$F_h = \text{_____} \text{ kHz.}$$

By subtracting the frequency of the lower 3dB corner from the frequency of the higher 3dB corner you get the bandwidth of the second IF amplifier.

Calculate the bandwidth by $(F_l - F_h)$

$$\text{Bandwidth} = \text{_____} \text{ kHz.}$$

Your results should be similar to the values shown in Figure 26. Turn the power OFF.

SECTION 4

FIRST AM IF AMPLIFIER

The operation of the first IF amplifier is the same as the second IF amplifier with one important difference. The gain of the first IF amplifier decreases after the AGC threshold is passed to keep the audio output constant at the detector and prevent overload of the second IF amplifier. This is accomplished by making the voltage on the base of transistor Q8 lower as the signal strength increases. Since the voltage from base to emitter is fairly constant, the drop in voltage at the base produces a similar drop in voltage at the

emitter of Q8. This drop lowers the voltage across R37 and thus, reduces the DC current through R37. Since all of the DC current from the emitter of Q8 must go through R37, the DC current in Q8 is therefore lowered. When the DC current in a transistor is lowered, its effective emitter resistance increases. The AC gain of transistor Q8 is equal to the AC collector load of Q8 divided by its effective emitter resistance. Raising the value of the effective emitter resistance, thus, lowers the AC gain of Q8.

ASSEMBLY INSTRUCTIONS

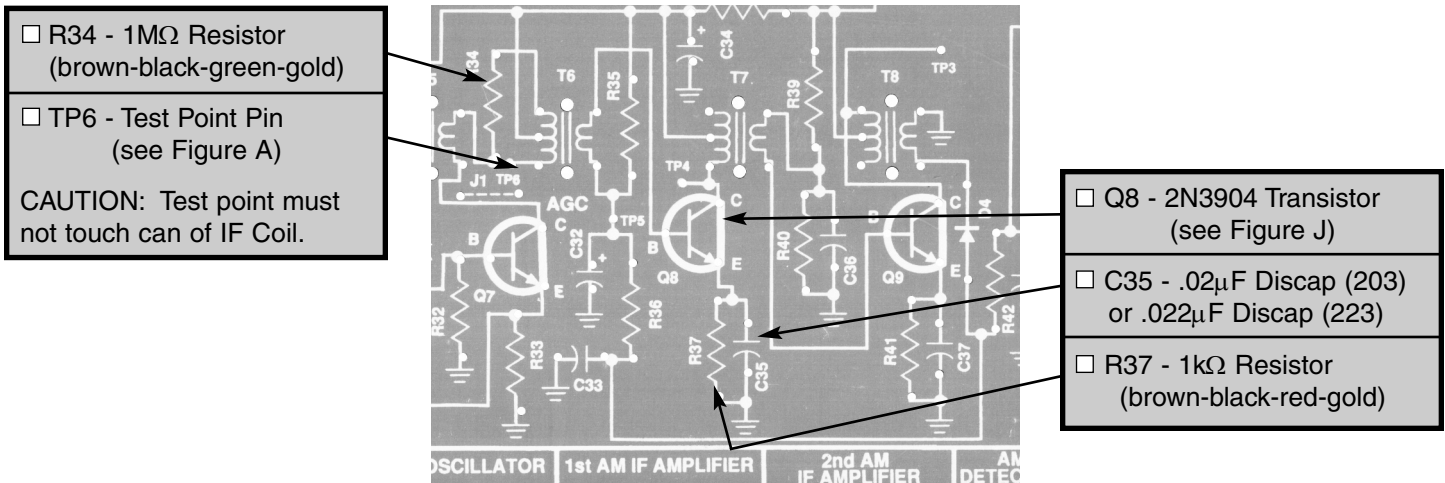

STATIC MEASUREMENTS

Q8 BASE BIAS

Connect your VOM to the circuit as shown in Figure 23. Set your VOM to read 2 volts DC and turn the power ON. The voltage at TP5 should be approximately 1.5 volts. If your circuit fails this test, check Q8 and R37. Turn the power OFF.

Q8 CURRENT

Connect the positive lead of your VOM to the emitter of Q8 and connect the negative lead to ground point TP15. Turn the power ON. The voltage should be approximately 0.8 volts. Since the current in Q8 is equal to the current in R37, $I(Q2) = 0.8/R37$ or approximately 0.8 milliamps. Turn the power OFF.

If you do not have an RF generator and oscilloscope, skip to Section 5.

DYNAMIC MEASUREMENTS

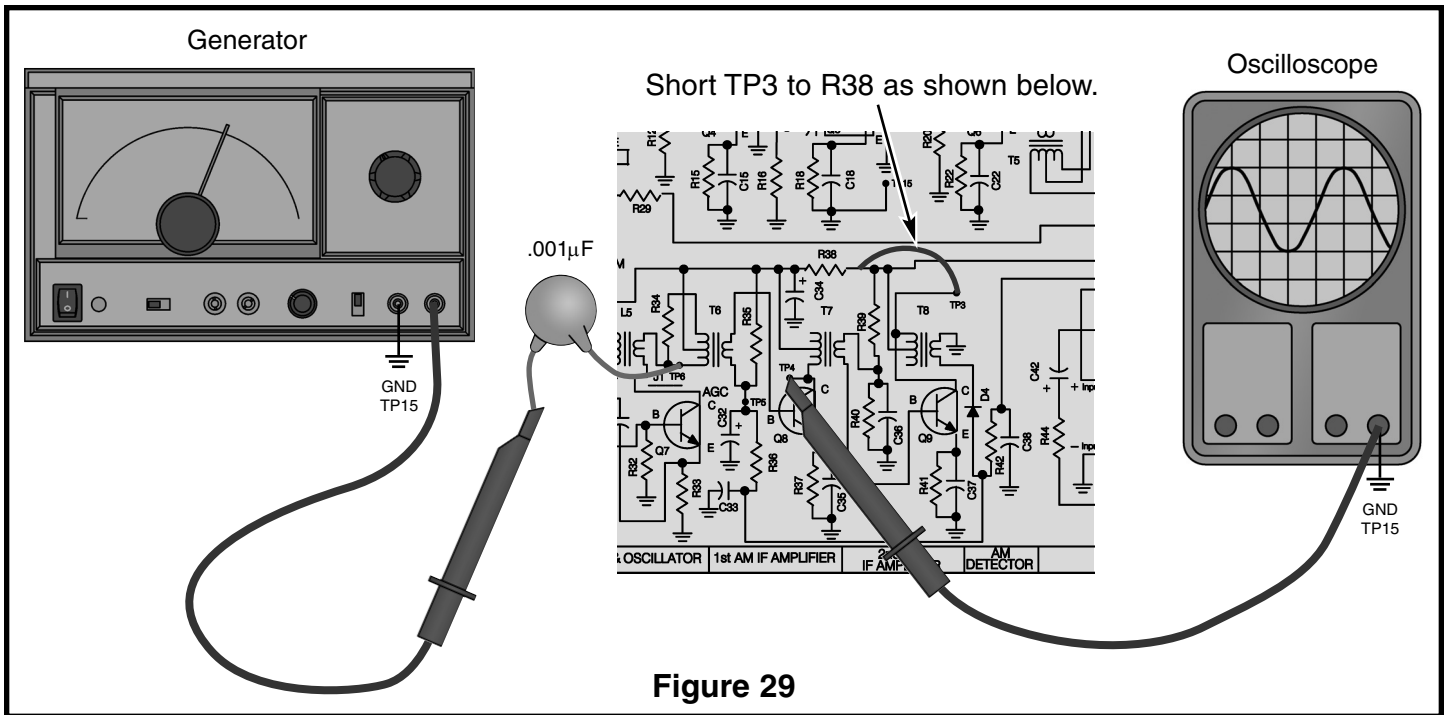

AC GAIN

Connect your test equipment as shown in Figure 29.

The scope probe must have an input capacitance of 12pF or less, otherwise it will detune transformer T7. Using a clip lead, short TP3 to R38 as shown. This short prevents the AGC from lowering the gain of the first IF amplifier. Set the generator to 455kHz, no modulation, and minimum voltage output. Set the scope to read 1 volt per division and turn the power ON. Increase the amplitude of the generator until approximately 4Vpp is seen on the scope. Retune the IF transformer T7 to maximize the 455kHz at TP4. After tuning T7, adjust the generator amplitude in order to keep 4Vpp at TP4. Now move the scope

probe to the base of Q8 and record the peak to peak level of the 455kHz signal here:

$$V_b = \text{_____} V_{pp}$$

The AC gain of the first IF amplifier is equal to $4/V_b$. The AC gain should be greater than 100. DO NOT TURN THE POWER OFF, GO TO THE NEXT TEST.

AGC ACTION

Move the scope probe back to TP4 and adjust the generator for 4Vpp if necessary. Remove the clip lead shorting TP3 to R38. The AGC should reduce the signal level at TP4 to approximately 0.8 volts. Turn the power OFF.

SECTION 5

AM MIXER, AM OSCILLATOR, AND AM ANTENNA

In a superheterodyne type receiver, the radio wave at the antenna is amplified and then mixed with the local oscillator to produce the intermediate frequency (IF). Transistor Q7 not only amplifies the RF signal, but also simultaneously oscillates at a frequency 455kHz above the desired radio station frequency. Positive feedback from the collector to the emitter of Q7 is provided by coil L5 and capacitor C31. During

the heterodyning process the following four frequencies are present at the collector of Q7.

1. The local oscillator frequency, OF.
2. The RF carrier or radio station frequency.
3. The sum of these two frequencies, OF + RF.
4. The difference of these two frequencies, OF - RF.

The “difference frequency” is used as the intermediate frequency in AM radios. The collector of Q7 also contains an IF transformer (T6) tuned only to the difference frequency. This transformer rejects all frequencies except those near 455kHz. T6 also couples the 455kHz signal to the base of Q8 to be processed by the IF amplifiers. The antenna and the oscillator coils are the only two resonant circuits that change when the radio is tuned for different stations. Since a radio station may exist 455kHz above the oscillator frequency, it is important that the antenna rejects this station and selects only the station

455kHz below the oscillator frequency. The frequency of the undesired station 455kHz above the oscillator is called the image frequency. If the selectivity of the antenna (Q factor) is high, the image will be reduced sufficiently.

The oscillator circuit must also change when the radio is tuned in order to remain 455kHz above the tuning of the desired radio station. The degree of accuracy in keeping the oscillator frequency exactly 455kHz above the tuning of the antenna is called tracking accuracy.

ASSEMBLY INSTRUCTIONS

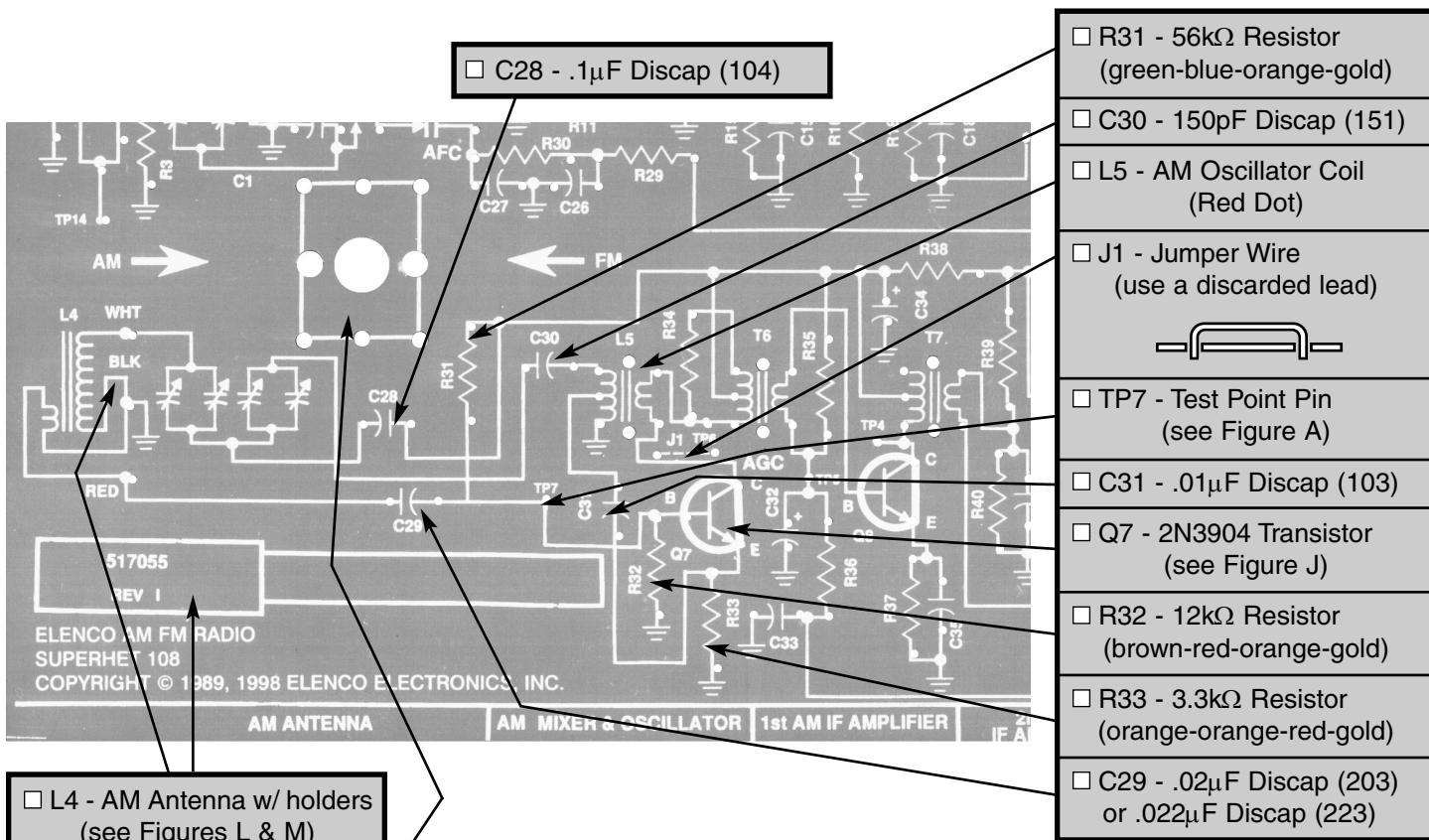

- L4 - AM Antenna w/ holders (see Figures L & M)
- C1 - Tuning Gang Capacitor
- 2 Screws M2.5 x 3.8mm (see Figure N)
- Knob (dial)
- Screw M2.5 x 7.5mm
- Label AM/FM (See Figure O)

Note: Mount the tuning gang capacitor to the foil (green) side of the PC board.

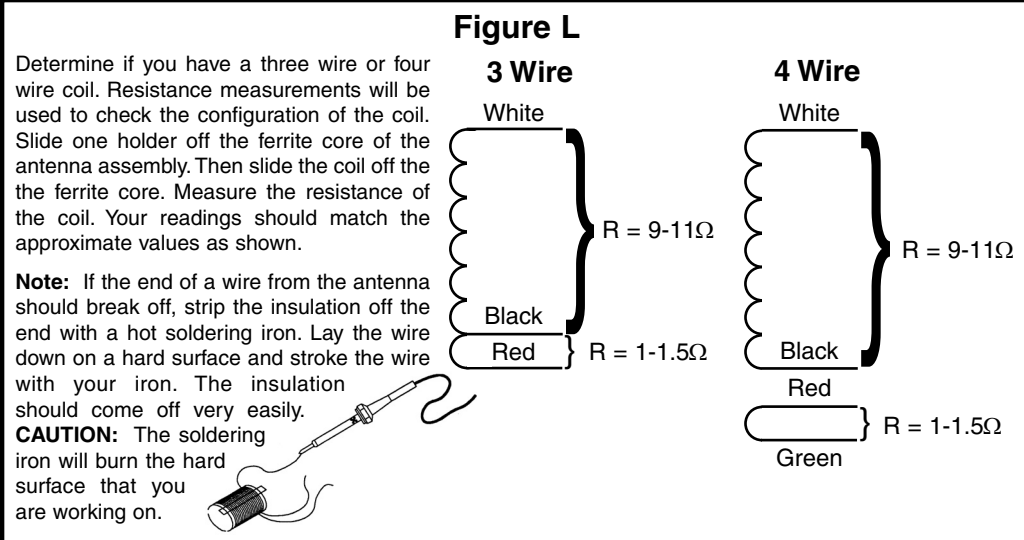



AMFM RADIO KIT
Model: AMFM108CK

Your kit contains a different tuning gang (299904) than the one illustrated on page 32, figure N. The middle lead with a hole indicates the FM side. Please use the figure below when installing the tuning gang to the PC board.

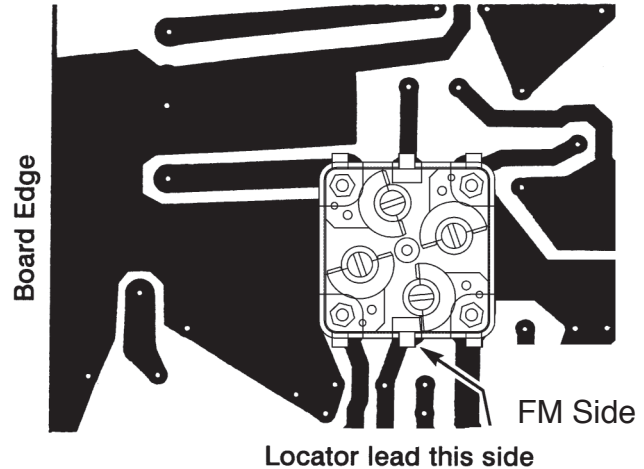
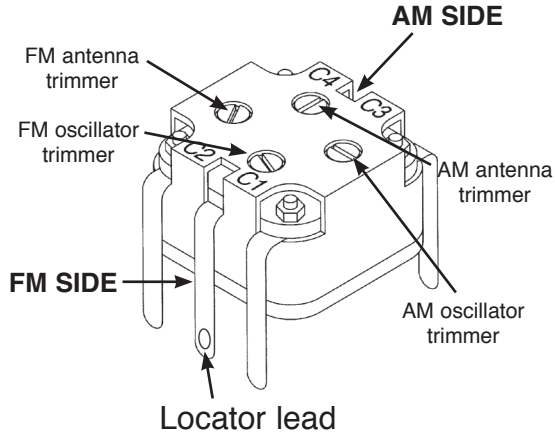

- Mount the tuning gang capacitor to the foil side of the PC board with the AM and FM sides in the correct direction.
- Fasten the gang in place with two screws from the front of the PC board.
- Solder the leads in place and cut off the excess leads coming through the PC board on the front side.

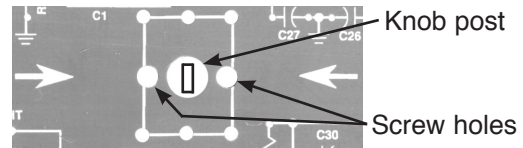

IMPORTANT: Before installing the antenna coil, determine if you have a 3 wire coil or a 4 wire coil. Assemble it to the PC board as shown below. Mount the antenna assembly to the PC board.

- Put the tab of the first holder into the right hole and twist the tab 90°.
- Put the tab of the second holder into the left hole and twist the tab 90°.
- Slide the ferrite core through the holders.
- Slide the antenna coil through the ferrite core.

Note: If the end of a wire from the antenna should break off, strip the insulation off the end with a hot soldering iron. Lay the wire down on a hard surface and stroke the wire with your iron. The insulation should come off very easily. **CAUTION:** The soldering iron will burn the hard surface that you are working on.

Punch out one antenna shim from the front flap of the box. Insert the cardboard antenna shim between the ferrite core and the antenna coil. This will temporarily hold the coil in place.

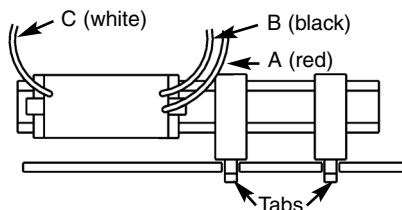
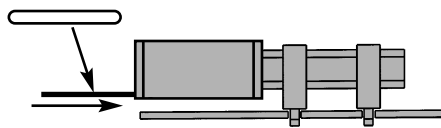

3 Wire Type Antenna: Solder the 3 colored wires to the PC board: Wire A (red) to the hole marked "RED", Wire B (black) to the hole marked "BLK" and Wire C (white) to the hole marked "WHT".

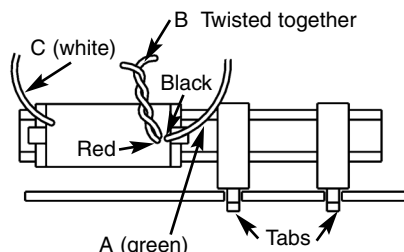

OR

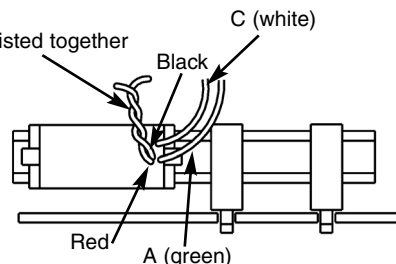

4 Wire Type Antenna: Solder the 4 colored wires to the PC board: Wire A (green) to the hole marked "RED", Wire B (red and black twisted together) to the hole marked "BLK" and Wire C (white) to the hole marked "WHT".

Figure M

It is important to know which of the two types of the tuning gang capacitor you have received with your kit. Look at the gang capacitor that you have.

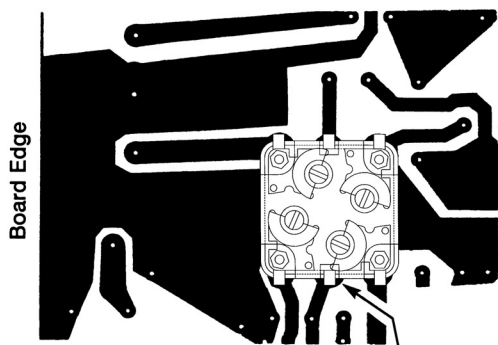
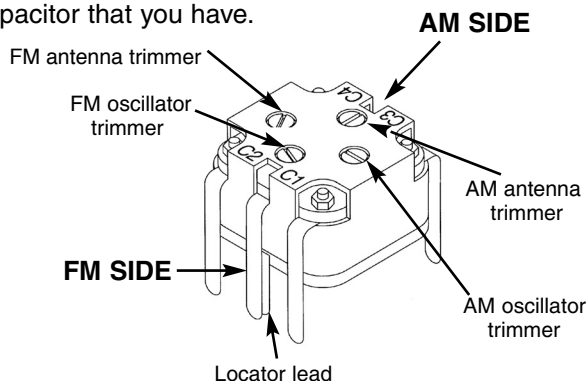

Locator lead this side
(Do not remove, but solder both leads together in hole).

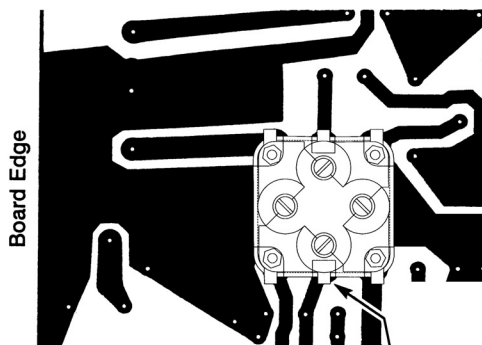
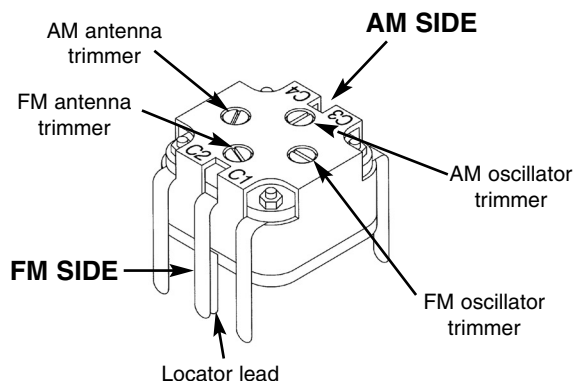

Locator lead this side
(Do not remove, but solder both leads together in hole).

- Mount the tuning gang capacitor to the foil side of the PC board with the AM and FM sides in the correct direction.
- Fasten the gang in place with two screws from the front of the PC board.
- Solder the leads in place and cut off the excess leads coming through the PC board on the front side.

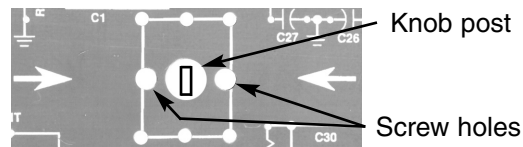
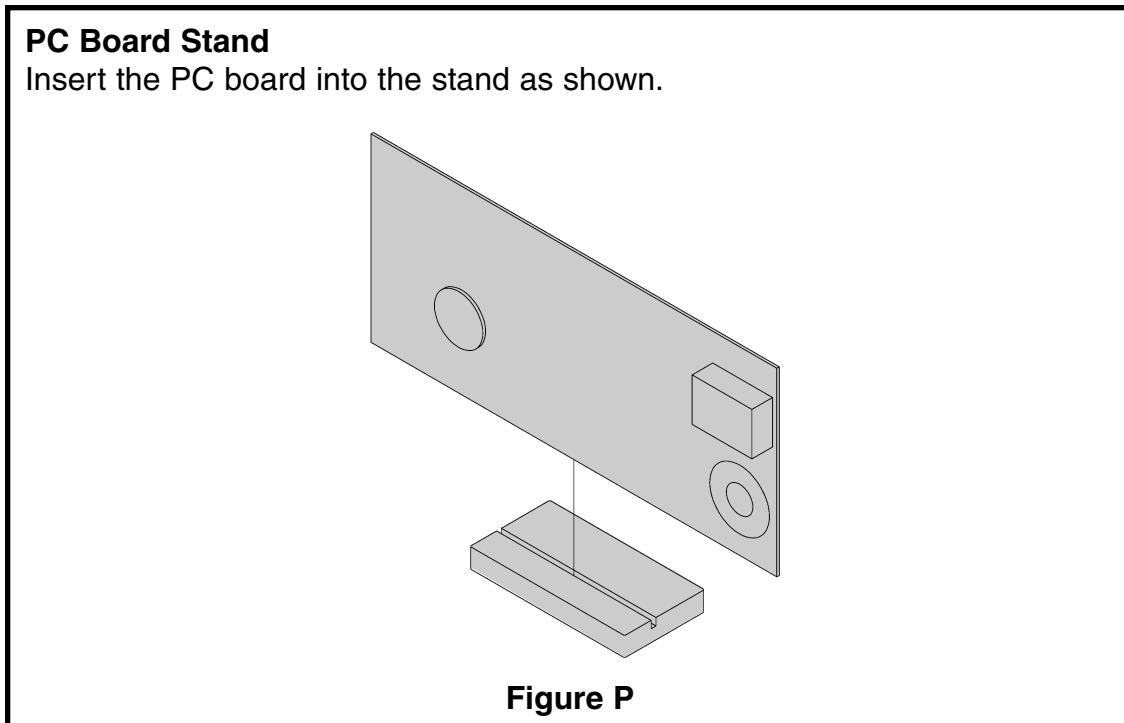
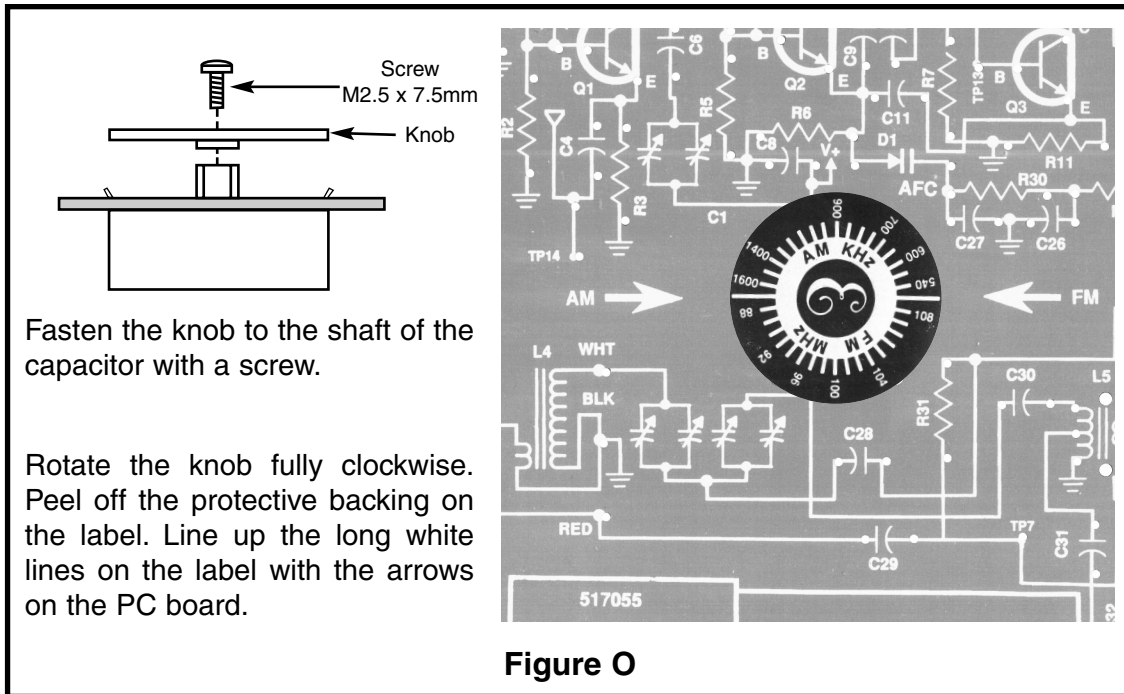

Figure N

ASSEMBLY INSTRUCTIONS



STATIC MEASUREMENTS

Q7 BIAS

Connect your VOM to the circuit as shown in Figure 30.

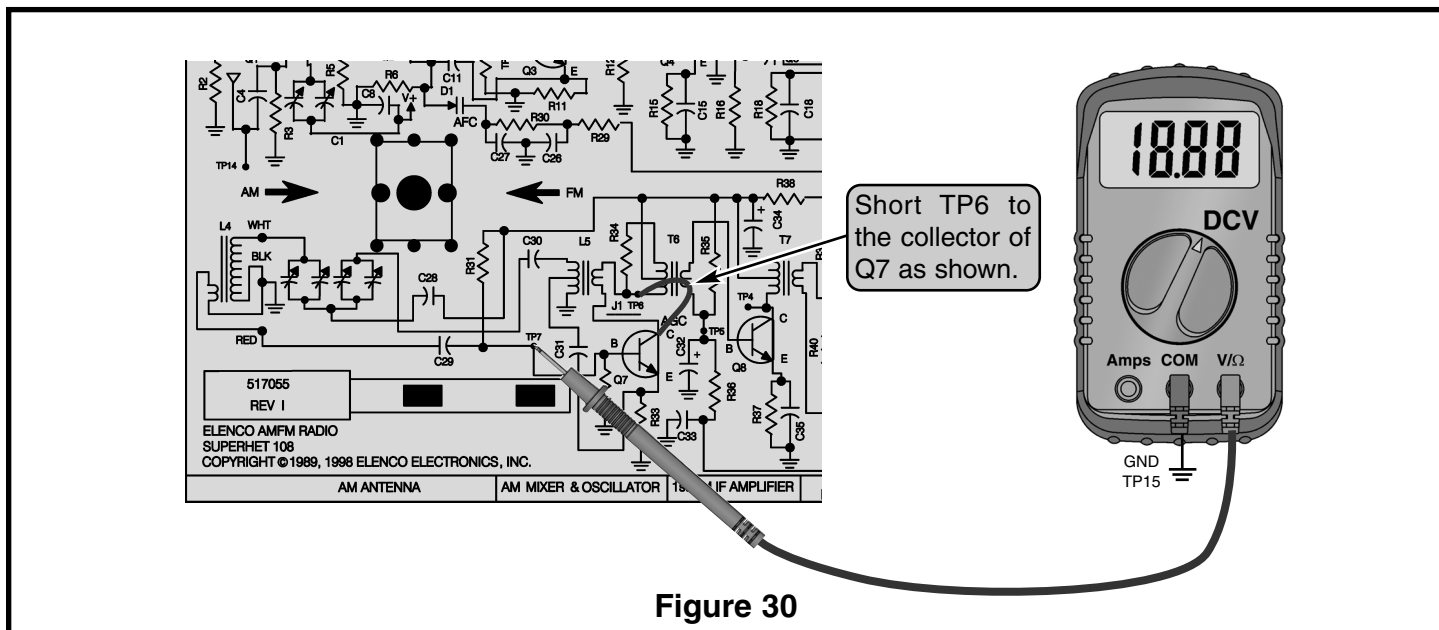

Connect a clip lead from TP6 to the collector of Q7. This short prevents Q7 from oscillating. Set the VOM to read 2 volts DC and turn the power ON. The DC voltage at TP7 should be about 1.6 volts. If the voltage in your circuit differs by more than 0.5 volts,

leave the power ON and check the battery voltage. If the battery voltage is greater than 8.5 volts, check components R31, R32, R33 and Q7. Turn the power OFF.

If you do not have an oscilloscope, skip to the AM Final Alignments.

DYNAMIC MEASUREMENTS

AM OSCILLATOR CIRCUIT

Connect your test equipment to the circuit as shown in Figure 31.

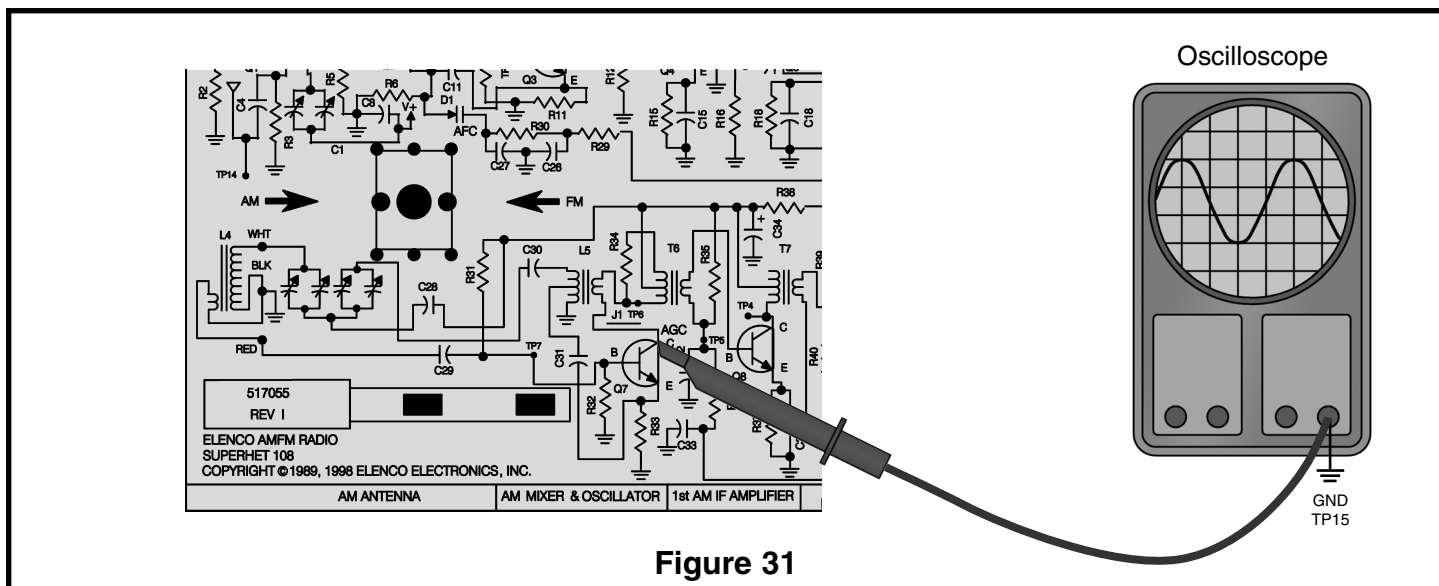

Set the scope to read 1 volt per division and turn the power ON. The scope should display a low voltage sinewave. The frequency of the sinewave should

change when the tuning gang is turned. If your circuit fails this test, check components Q7, gang capacitor, C28, C29, C30, C31, L4 and L5. Turn the power OFF.

AM FINAL ALIGNMENTS

There are two different AM alignment procedures. The first alignment procedure is for those who do not have test equipment and the second is for those who do have test equipment.

Included in your kit is a special device called a “magic wand” which is used for aligning resonant circuits. It usually has a piece of brass on one end and a piece of iron on the other. When the brass end of the “magic wand” is placed near the AM antenna, the antenna coil will react as if inductance has been removed. Likewise, when the iron end of the “magic wand” is placed near the AM antenna, the antenna coil will react as if inductance has been added. Therefore, when either brass or iron is placed near the antenna coil, it will change the inductance of the antenna coil. This change in the inductance will cause the resonant frequency of the circuit to change, thus changing the frequency at which the antenna was selective. When aligning the antenna and oscillator circuits, coils L4 and L5 are adjusted at the lower end of the band, while the oscillator and antenna trimmer capacitors are adjusted at the higher end of the band. This is done so that the antenna and the oscillator will track correctly.

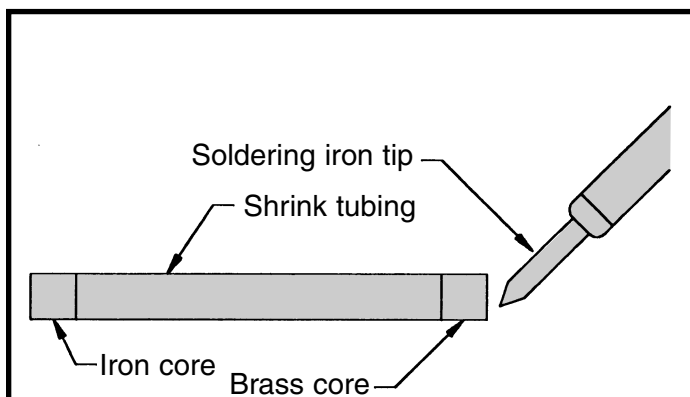

Magic Wand Assembly

Place the piece of brass inside the end of the shrink tubing, with 1/4” outside. Heat the brass up with your soldering iron until the tubing shrinks around the brass. Assemble the iron piece to the other end in the same manner.

AM ALIGNMENT WITHOUT TEST EQUIPMENT

It is best to use an earphone for this procedure. Make sure that the switch is in the AM position. With an alignment tool or screwdriver, turn coils L5, T6, T7 and T8 fully counter clockwise until they stop. DO NOT FORCE THE COILS ANY FURTHER. Turn each coil in about 1 1/4 to 1 1/2 turns. Set the AM antenna coil about 1/8” from the end of its ferrite rod. Refer to Figure M.

IF ALIGNMENT

Turn the power ON and adjust the volume to a comfortable level. Turn the dial until a weak station is heard. If no stations are present, slide the antenna back and forth on its ferrite core, and retune the dial if necessary. Adjust T6 until the station is at its loudest. Reduce the volume if necessary. Adjust T7 until the station is at its loudest and reduce the volume if necessary. Adjust T8 until the station is at its loudest and reduce the volume if necessary. Retune the radio for another weak station and repeat this procedure until there is no more improvement noticed on the weakest possible station. This process peaks the IF amplifiers to their maximum gain.

OSCILLATOR ALIGNMENT

Tune the radio until a known AM station around 600kHz is heard. It may be necessary to listen to the station until their broadcast frequency is announced. If no stations are present at the low side of the AM band, adjust L5 until a station is heard. Once a station is found and its broadcast frequency is known, rotate the dial until the white pointer is aligned to that station’s frequency marking on the dial. Adjust L5 until the station is heard. Tune the radio until a known station around 1400kHz is heard. It may be necessary to listen to the station until their broadcast frequency is announced. If no stations are present, adjust the AM oscillator trimmer on the gang until a station is heard (refer to Figure N). Once a station is found and its broadcast frequency is known, rotate the dial until the white pointer is aligned to that station’s frequency marking on the dial. Adjust the AM oscillator trimmer on the gang until the station is heard. Repeat these 2 steps until the oscillator alignment is optimized. This process sets the oscillator range at 955kHz to 2055kHz.

ANTENNA ALIGNMENT

Tune the radio for a station around 600kHz. With the “magic wand” place the brass end near the antenna coil as shown in Figure 32. If the signal heard at the output increases, it means that the antenna coil needs less inductance. To remove inductance, carefully slide the antenna coil along its ferrite core in the direction shown in Figure 32. Place the iron end of the “magic wand” near the antenna coil. If the signal heard at the output increases, this means that the antenna coil needs more inductance. To add more inductance, carefully slide the antenna coil along its ferrite core in the direction shown in Figure 32. Repeat these steps until the signal heard decreases for both ends of the “magic wand”. Tune the radio for a station around 1400kHz. With the “magic wand”, place the brass end near the antenna coil. If the signal heard at the output increases, it means that the antenna coil needs more capacitance. Adjust the antenna trimmer on the back of the gang until the signal is at its loudest. Refer to Figure N for the location of the antenna trimmer. Place the iron end of the “magic wand” near the antenna coil. If the signal heard at the output increases, it means that the antenna coil needs less capacitance. Adjust the antenna trimmer on the back of the gang until the signal is at its loudest. Repeat these steps until the signal heard decreases for both ends of the “magic wand”. Since the adjustment of both the antenna trimmer and antenna coil will effect the antenna alignment, it is advisable to repeat the entire procedure until the antenna alignment is optimized. This process sets the tracking of the AM radio section.

Once the antenna is properly aligned, CAREFULLY APPLY CANDLE WAX or glue to the antenna coil and the ferrite rod to prevent it from moving (see Figure 33). Cut the shim flush with the antenna.

This concludes the alignment of the AM radio section. If no stations are heard, verify that AM signals are present in your location by listening to another AM radio placed near the Superhet 108. If the AM section is still not receiving, go back and check each stage for incorrect values and for poor soldering. Proceed to the FM assembly section.

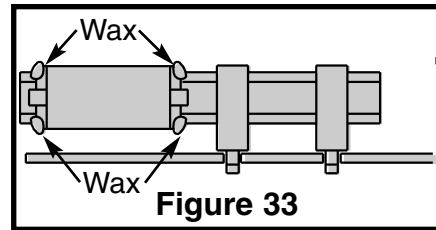
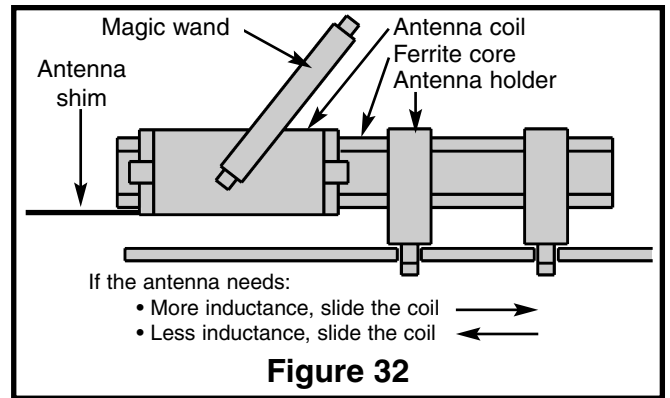

AM ALIGNMENT WITH TEST EQUIPMENT IF ALIGNMENT

Connect your RF generator and oscilloscope as shown in Figure 34. Make sure that the switch is in

the AM position. **Place a short from the collector of Q7 to TP6.** This short “kills” the AM oscillator.

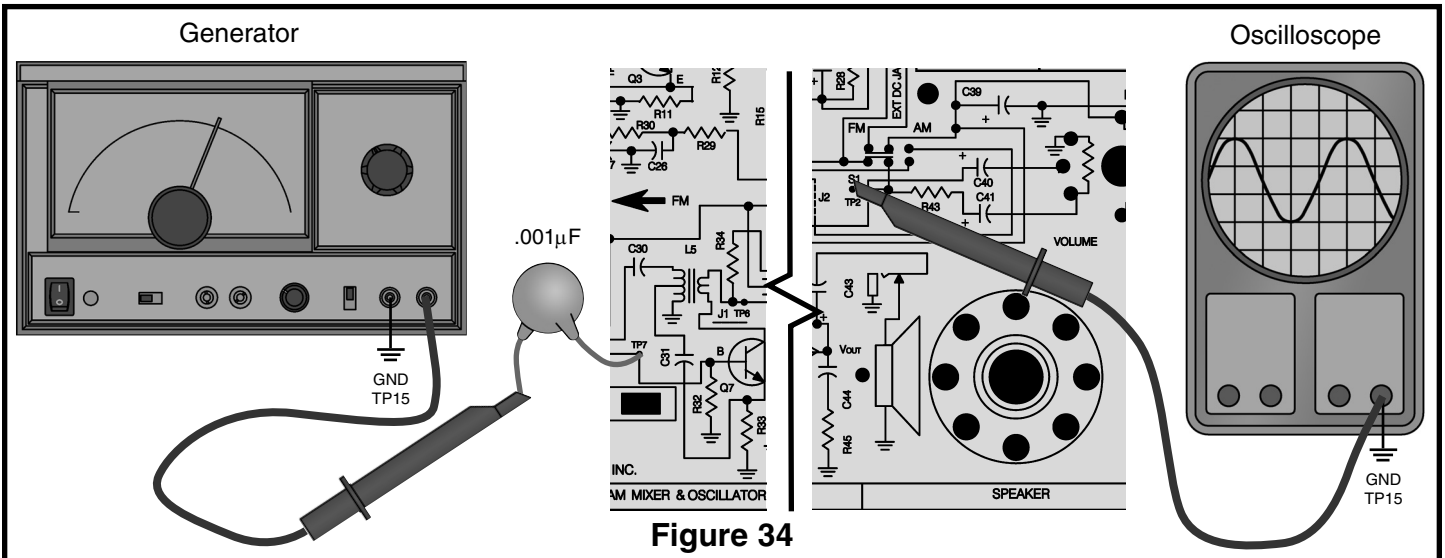

Set the RF generator at 455kHz, modulation of 400Hz 80% and minimum voltage out. Set the oscilloscope to read 0.1 volts per division and turn the power ON. Increase the amplitude of the generator until the oscilloscope shows a 400Hz sinewave 5 divisions or 0.5 volts pp. With an alignment tool or screwdriver adjust T6 for a peak. Reduce the generator amplitude so that 5 divisions are maintained. Adjust T7 for a peak and reduce that amplitude again if necessary. Repeat these steps to optimize the IF alignment. This process aligns the IF amplifiers to 455kHz.

After the IF alignment is complete, lower the frequency of the generator until the voltage drops 0.707 of its peaked value or 0.35Vpp. Record the frequency of the lower 3dB corner here:

$$F_l = \text{_____ kHz.}$$

Increase the frequency of the generator past the peak until the voltage seen on the scope drops 0.707 of its peaked value or 0.35Vpp. Record the frequency of the high 3dB corner here:

$$F_h = \text{_____ kHz.}$$

The bandwidth of the IF is equal to $BW = F_h - F_l$. The IF's bandwidth should be around 6kHz. Turn the power OFF and **remove the short from the collector of Q7 to TP6**.

Calculate the bandwidth: _____ kHz.

OSCILLATOR ALIGNMENT

Set the RF generator at 540kHz, 400Hz 80% AM modulation and a low level of output. Turn the power ON and set the volume control to a comfortable level. Turn the tuning knob counter-clockwise until the white pointer is aligned at the 540kHz marking on the dial. With an alignment tool or screwdriver adjust L5 until a 400Hz tone is heard. Adjust L5 for a peak on the oscilloscope. Adjust the amplitude of the RF generator to maintain a level of 0.5 volts peak to peak or less. After peaking L5, set the generator frequency to 1600kHz. Turn the tuning knob clockwise until the white pointer is aligned to the 1600kHz marking on the dial. With an alignment tool or screwdriver, adjust the AM oscillator trimmer on the back of the tuning gang until a 400Hz tone is heard. Adjust the trimmer for a peak on the oscilloscope. Refer to Figure N for the location of the AM oscillator trimmer. Repeat these steps to optimize the oscillator alignment. This process sets the oscillator range at 955kHz to 2055kHz.

ANTENNA ALIGNMENT

With the power turned OFF, connect your test equipment as shown in Figure 35.

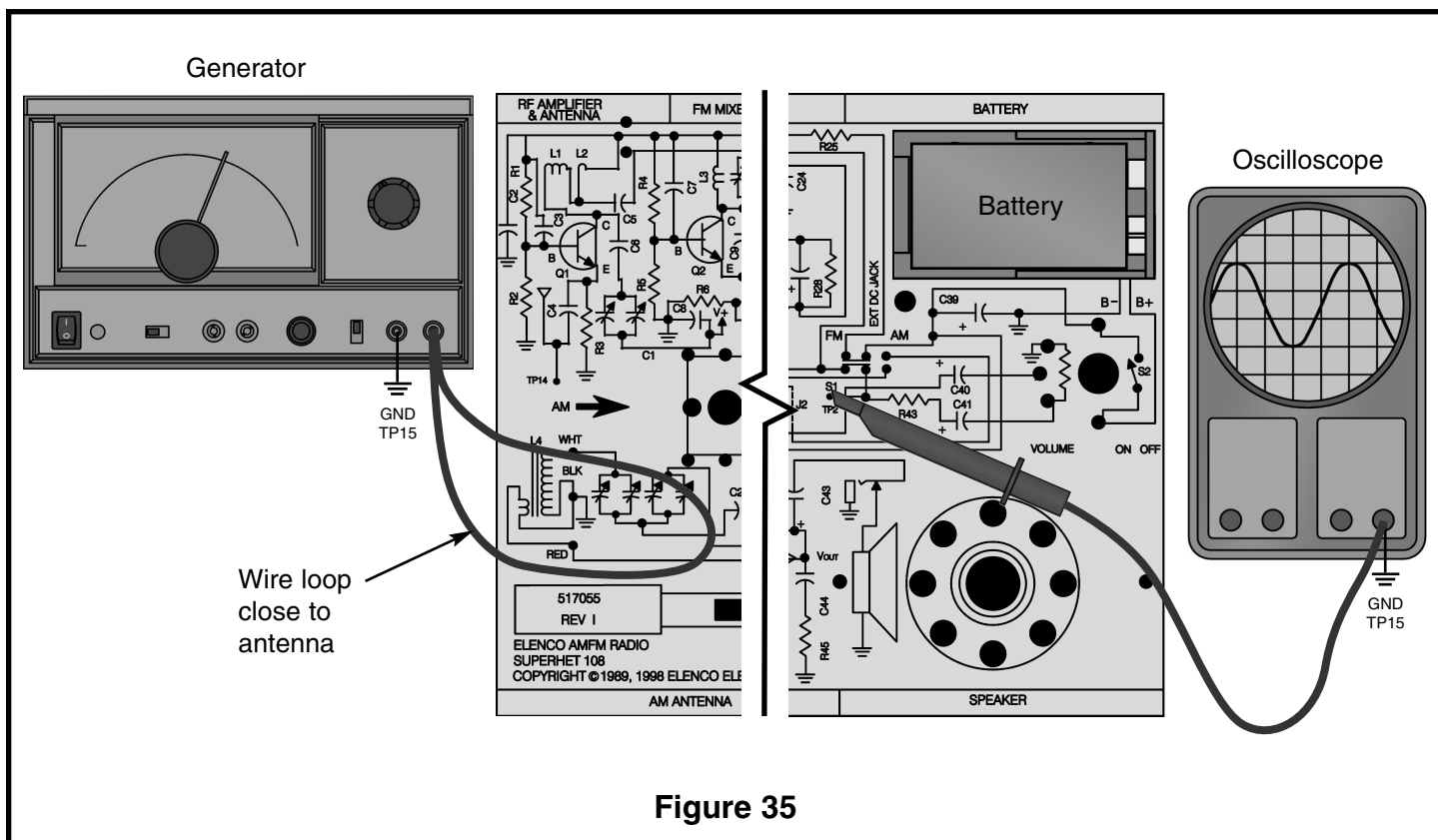

Figure 35

Set the generator at 600kHz, 400Hz 80% modulation, moderate signal strength. Set the oscilloscope to read 0.1 volt per division. Turn the tuning knob fully counter-clockwise and turn the power ON. Slowly turn the tuning knob clockwise until a 400Hz sinewave is seen on the scope. Adjust the volume control to a comfortable level. If a station exists at 600kHz, then lower the frequency of the generator and repeat the previous steps. With the “magic wand”, place the brass end near the antenna coil as shown in Figure 32. If the signal on the scope increases, it means that the antenna coil needs less inductance. To add more inductance, carefully slide the antenna coil along its ferrite core in the direction shown in Figure 32. Repeat these steps until the signal seen decreases for both ends of the “magic wand”. Increase the frequency of the generator to 1400kHz and turn the tuning knob clockwise until a 400Hz sinewave is seen on the scope. If a station exists at 1400kHz, increase the frequency of the generator and repeat the previous steps. Place the

brass end of the “magic wand” near the antenna coil. If the signal increases, it means that the antenna coil needs less capacitance. Adjust the antenna trimmer for a peak. Refer to Figure N for the location of the AM antenna trimmer. Since the adjustment of both the antenna alignment is optimized. This process sets the AM tracking of the Superhet 108.

Once the antenna is properly aligned, carefully apply candle wax or glue the antenna coil to the ferrite rod to prevent it from moving as shown in Figure 33. Cut the shim flush with the antenna. Proceed to the FM assembly section.

This concludes the alignment of the AM radio section. If no stations are heard, verify that AM signals are present in your location by listening to another AM radio placed near the Superhet 108. If the AM section is still not receiving, go back and check each stage for incorrect values and for poor soldering. Proceed to the FM assembly section.

AM RADIO HIGHLIGHTS

1. The number of vibrations (or cycles) per second produced by a sound is called the frequency, and is measured in hertz.
2. The distance between peaks of sound waves is called the wavelength.
3. Sound waves are produced as a certain number of vibrations per second. The more vibrations per second, the higher the frequency; the fewer vibrations, the lower the frequency.
4. Waves of very high frequency are called radio waves and travel great distances through the air without the use of wires.
5. Carrier waves are radio waves used by broadcast stations to carry audio waves.
6. The process of adding the audio waves to the radio waves is called modulation, and the process of removing the radio wave from the audio wave is called demodulation, which is performed in an AM radio by the detector.
7. The amount of signal picked up by the antenna will depend on the power of the signal transmitted and the distance the signal travelled.
8. Rectification is the process of removing half the signal, while filtering is the process of smoothing that signal.
9. Heterodyning is the process of mixing two signals (the incoming RF signal and the RF signal from the local oscillator) to produce a third signal (the IF signal).

DC VOLTAGES

The voltage readings below should be used in troubleshooting the AM section (switch at AM position).

Q7	B	1.5	U1	1	1.3	Q10	B	0.7	Q13	B	8.4
	E	1.0		2	0		E	0.06		E	9.0
	C	8.8		3	0		C	3.1		C	3.7
TP5 (AGC)		1.4		4	0	Q11	B	4.2	Q14	B	0.6
Q8	B	1.4		5	4.5		E	3.7		E	0
	E	0.8		6	9.0		C	8.4		C	3.7
	C	8.8		7	4.4	Q12	B	3.1	TP19		3.7
Q9	B	1.7	TP1		4.5		E	3.7			
	E	1.0					C	0.6			
	C	9.0									

Test Conditions

1. Volume set to minimum.
2. Connect side of capacitor C29 (that goes to L4) to TP15 with a jumper wire.
3. Battery voltage = 9V
4. All voltages are referenced to circuit common.
5. Voltage readings can vary $\pm 10\%$

QUIZ - AM RADIO SECTION

INSTRUCTIONS: Complete the following examination, check your answers carefully (answers on previous page).

1. The number of cycles produced per second by a source of sound is called the ...
 - A) amplitude.
 - B) vibration.
 - C) sound wave.
 - D) frequency.
2. The radio frequencies used by AM broadcast stations are between ...
 - A) 20kHz and 400kHz.
 - B) 5kHz and 20kHz.
 - C) 2400kHz and 6000kHz.
 - D) 550kHz and 1600kHz.
3. The process of removing the audio wave from the radio wave is called ...
 - A) demodulation.
 - B) frequency reduction.
 - C) modulation.
 - D) vibrating.
4. When an electromagnetic wave (modulated radio wave) passes an antenna, it ...
 - A) induces a voltage and current in the antenna.
 - B) changes an audio wave into a radio wave.
 - C) changes the carrier frequency.
 - D) produces sidebands.
5. The power of the signal transmitted by the broadcast station and the distance, the signal travelled from the transmitter to the receiver, determine the ...
 - A) frequency of the modulation.
 - B) wavelength of the audio waves.
 - C) amount of signal picked up by the antenna.
 - D) type of filter that is used.
6. When the two metal plates on a variable capacitor are unmeshed the ...
 - A) capacitance is minimum.
 - B) capacitance is maximum.
 - C) capacitance is not affected.
 - D) inductance is increased.
7. The process of mixing two signals to produce a third signal is called ...
 - A) filtering.
 - B) detecting.
 - C) rectification.
 - D) heterodyning.
8. The magic wand is used to determine ...
 - A) whether more or less inductance is required in a tuned circuit.
 - B) whether more or less capacitance is required in a tuned circuit.
 - C) the gain of an RF amplifier.
 - D) whether the oscillator is functioning.
9. The IF frequency of your AM radio is ...
 - A) 1600kHz.
 - B) 455kHz.
 - C) 550kHz.
 - D) 910kHz.
10. The purpose of the AGC circuit is to ...
 - A) automatically control the frequency of the oscillator circuit.
 - B) control the band width of the IF stages.
 - C) reduce distortion in the audio circuit.
 - D) maintain a constant audio level at the detector, regardless of the strength of the incoming signal.

PARTS LIST FOR FM SECTION

RESISTORS

Qty.	Symbol	Value	Color Code	Part #
□ 2	R9, 23	100Ω 5% 1/4W	brown-black-brown-gold	131000
□ 1	R25	220Ω 5% 1/4W	red-red-brown-gold	132200
□ 1	R3	470Ω 5% 1/4W	yellow-violet-brown-gold	134700
□ 5	R18, 22, 24, 26, 27	1kΩ 5% 1/4W	brown-black-red-gold	141000
□ 1	R11	1.8kΩ 5% 1/4W	brown-gray-red-gold	141800
□ 2	R6, 15	2.2kΩ 5% 1/4W	red-red-red-gold	142200
□ 2	R2, 7	6.8kΩ 5% 1/4W	blue-gray-red-gold	146800
□ 7	R10,12,14,16,19,20,28	10kΩ 5% 1/4W	brown-black-orange-gold	151000
□ 2	R1, 8	22kΩ 5% 1/4W	red-red-orange-gold	152200
□ 2	R4, 5	33kΩ 5% 1/4W	orange-orange-orange-gold	153300
□ 3	R13, 17, 21	47kΩ 5% 1/4W	yellow-violet-orange-gold	154700
□ 2	R29, 30	390kΩ 5% 1/4W	orange-white-yellow-gold	163900

CAPACITORS

Qty.	Symbol	Value	Description	Part #
□ 1	C9	15pF	Discap (15)	211510
□ 1	C10	30pF	Discap (30)	213010
□ 1	C6	33pF	Discap (33)	213317
□ 1	C11	220pF	Discap (221)	222210
□ 2	C4, 5	470pF	Discap (471)	224717
□ 3	C3, 7, 27	0.001μF	Discap (102)	231036
□ 3	C2, 8, 12	0.005μF	Discap (502)	235018
□ 10	C13 - 22	0.01μF	Discap (103)	241031
□ 1	C23	0.02μF or 0.022μF	Discap (203) or (223)	242010
□ 1	C26	0.1μF	Discap (104)	251010
□ 1	C25	10μF	Electrolytic radial (Lytic)	271045
□ 1	C24	470μF	Electrolytic radial (Non-Polarized)	284764

SEMICONDUCTORS

Qty.	Symbol	Value	Description	Part #
□ 1	D1	FV1043	Varactor diode	310176
□ 2	D2, 3	1N34A	Point-contact germanium diode	311034
□ 6	Q1 - Q6	2N3904	Transistor NPN	323904

COILS

Qty.	Symbol	Value	Description	Part #	Qty.	Symbol	Value	Description	Part #
□ 1	T5	Blue	FM detector	430110	□ 1	L1	6 Turns	FM RF amp	430160
□ 1	T4	Pink	FM detector	430120	□ 1	L2	2 Turns	FM RF amp	430170
□ 2	T2, T3	Green	FM IF	430130	□ 1	L3	5 Turns	FM oscillator	430180
□ 1	T1	Orange	FM mixer	430140					

MISCELLANEOUS

Qty.	Symbol	Description	Part #	Qty.	Symbol	Description	Part #
□ 1		Antenna FM	484005	□ 2		Nut M1.8	644210
□ 2		Screw M1.8 x 7.5mm	641100	□ 7	TP8 - 14	Test point pin	665008
□ 2		Screw M2 x 5mm (antenna)	643148	□ 1		Coil spacer	669108

PARTS IDENTIFICATION

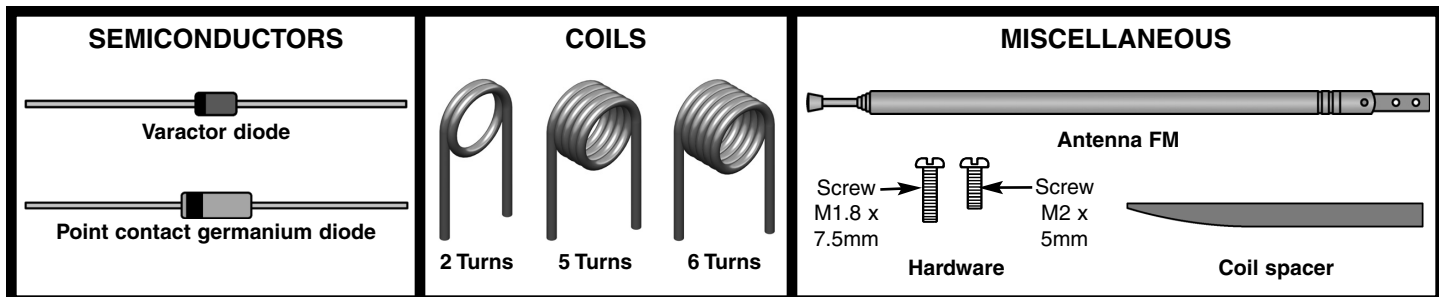

SECTION 6

THE FM RADIO

Section 6 begins the construction of the FM radio. The stages that we will build are shown in the block diagram below. We will begin with the FM Ratio

Detector and work back to the FM Antenna. Each stage will be tested before proceeding to the next stage.

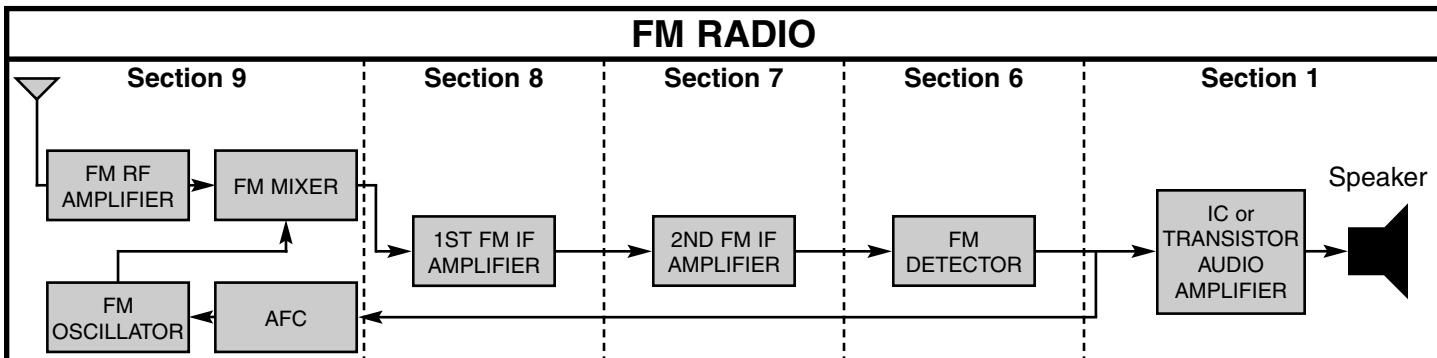

FM RATIO DETECTOR

In the AM DETECTOR section we observed that the audio was detected from changes in the amplitude of the incoming signal. In FM detection, the audio is detected from changes in frequency of the incoming signal. The RATIO DETECTOR has built-in limiting action which limits the signal so that any noise riding on the FM carrier will be minimized. The RATIO DETECTOR is redrawn below for ease of explanation.

When an incoming signal is present at T4 and T5, a current flows through D2, R26, R28, R27 and D3. At no modulation, the current through the diodes D2 and D3 are equal because T5 is center-tapped.

Thus, no current is drawn through C23 resulting in zero audio output voltage. When the incoming signal is modulated, the current through one diode will be greater than the other. This causes a current to flow in C23 which will produce an audio voltage across C23. If the modulation is of opposite direction than before, more current will flow in the other diode, which will again cause current to flow in C23 in the opposite direction resulting in an audio voltage being produced across C23. The large current drawn from the audio which causes the battery voltage to vary. The ratio detector is decoupled further by the resistor R23 and capacitor C21.

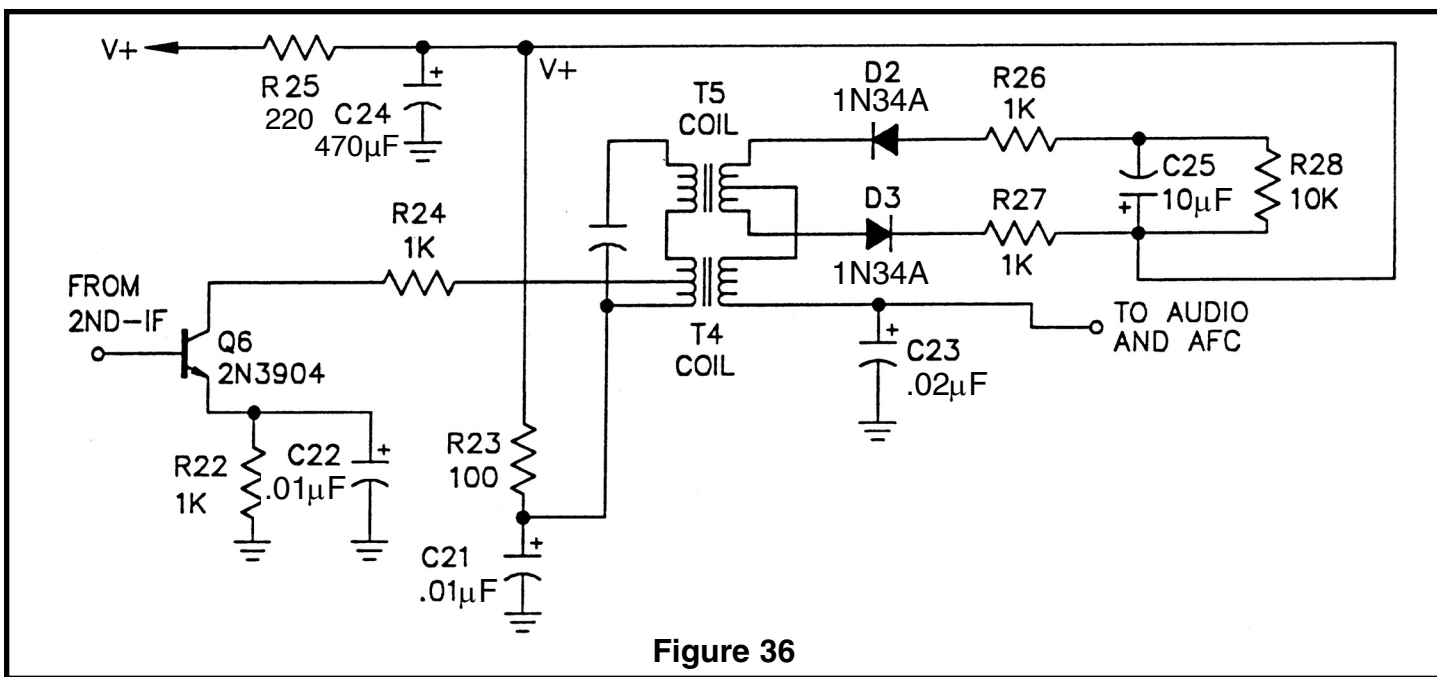
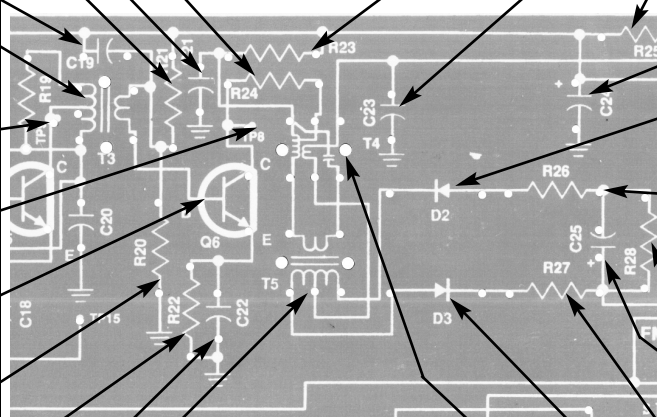

Figure 36

ASSEMBLY INSTRUCTIONS

- R24 - 1k Ω Resistor (brown-black-red-gold)
- C21 - .01 μ F Discap (103)
- R21 - 47k Ω Resistor (yellow-violet-orange-gold)
- C19 - .01 μ F Discap (103)
- T3 - FM IF Coil (Green Dot)
- TP9 - Test Point Pin (see Figure Q)
- TP8 - Test Point Pin (see Figure Q)
- Q6 - 2N3904 Transistor (see Figure R)
- R20 - 10k Ω Resistor (brown-black-orange-gold)
- R22 - 1k Ω Resistor (brown-black-red-gold)
- C22 - .01 μ F Discap (103)
- T5 - FM Detector Coil (Blue Dot)



- R23 - 100 Ω Resistor (brown-black-brown-gold)
- C23 - .02 μ F Discap (203) or .022 μ F Discap (223)
- R25 - 220 Ω Resistor (red-red-brown-gold)
- C24 - 470 μ F Non-Polarized Lytic (see Figure S)
- D2 - 1N34A Diode (see Figure T)
- R26 - 1k Ω Resistor (brown-black-red-gold)
- R28 - 10k Ω Resistor (brown-black-orange-gold)
- C25 - 10 μ F Lytic (see Figure S)
- R27 - 1k Ω Resistor (brown-black-red-gold)
- D3 - 1N34A Diode (see Figure T)
- T4 - FM Detector Coil (Pink Dot) (see Figure U)

Test Point Pin

Legend side of PC board (blue side)

Foil side of PC board (green side)

Figure Q

NPN Transistor

Mount so E lead is in the arrow hole and flat side is in the same direction as shown on the top legend. Leave 1/4" between the part and PC board.

1/4" Flat side

Figure R

Lytic Capacitor

Be sure that the negative (short) lead is in the correct hole on the PC board.

Polarity mark

Warning:
If the capacitor is connected with incorrect polarity, it may heat up and either leak, or cause the capacitor to explode.

Non-Polarized Capacitor

Insert leads in either direction.

Figure S

Diode

Be sure that the band is in the same direction as marked on the PC board.

Band Anode Cathode

Figure T

FM Detector Coil (T4)

Notch Line

AMPLIFIER

FM RATIO DETECTOR

Note: The line or notch must be pointing to the top of the PC board. Some FM detector coils have a part number in place of the line/notch.

Figure U

STATIC MEASUREMENTS

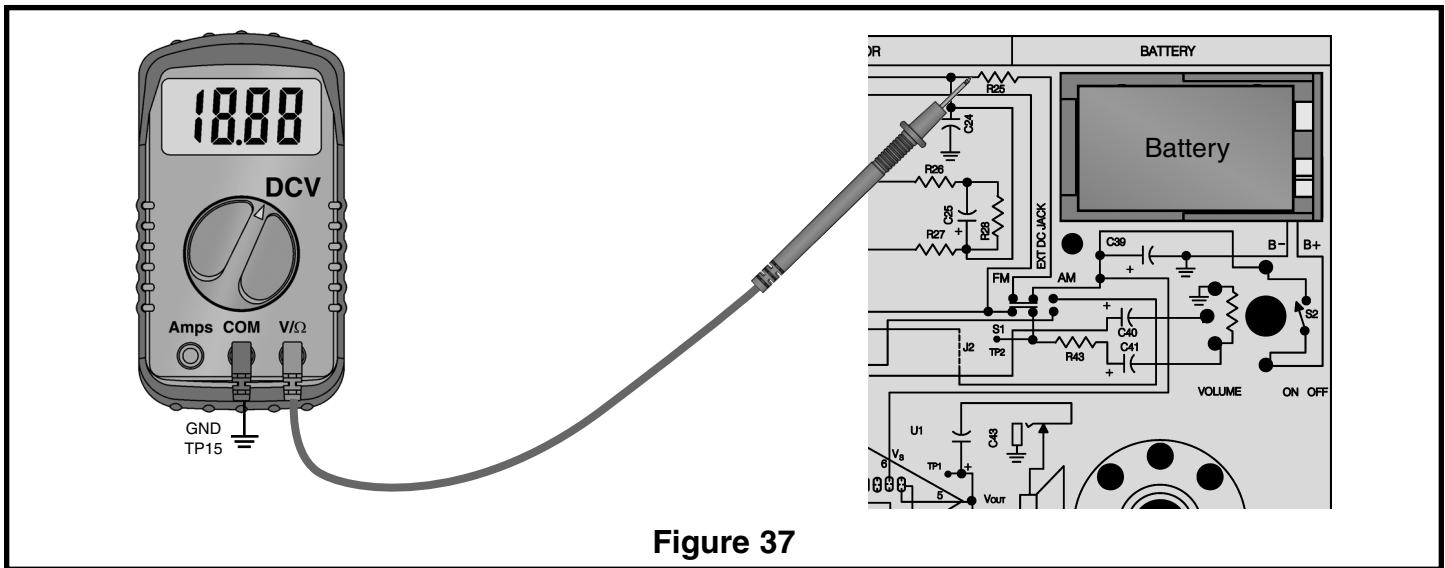

Figure 37

FM VOLTAGE

Connect your VOM as shown in Figure 37. Switch the AM/FM switch to the FM position. Set your VOM to read 9 volts DC. Turn the power ON. The voltage at

this point should be between 7 and 9 volts. Turn the power OFF. If you do not get this reading, check R25, C24 and the battery voltage.

TRANSISTOR CURRENT TEST

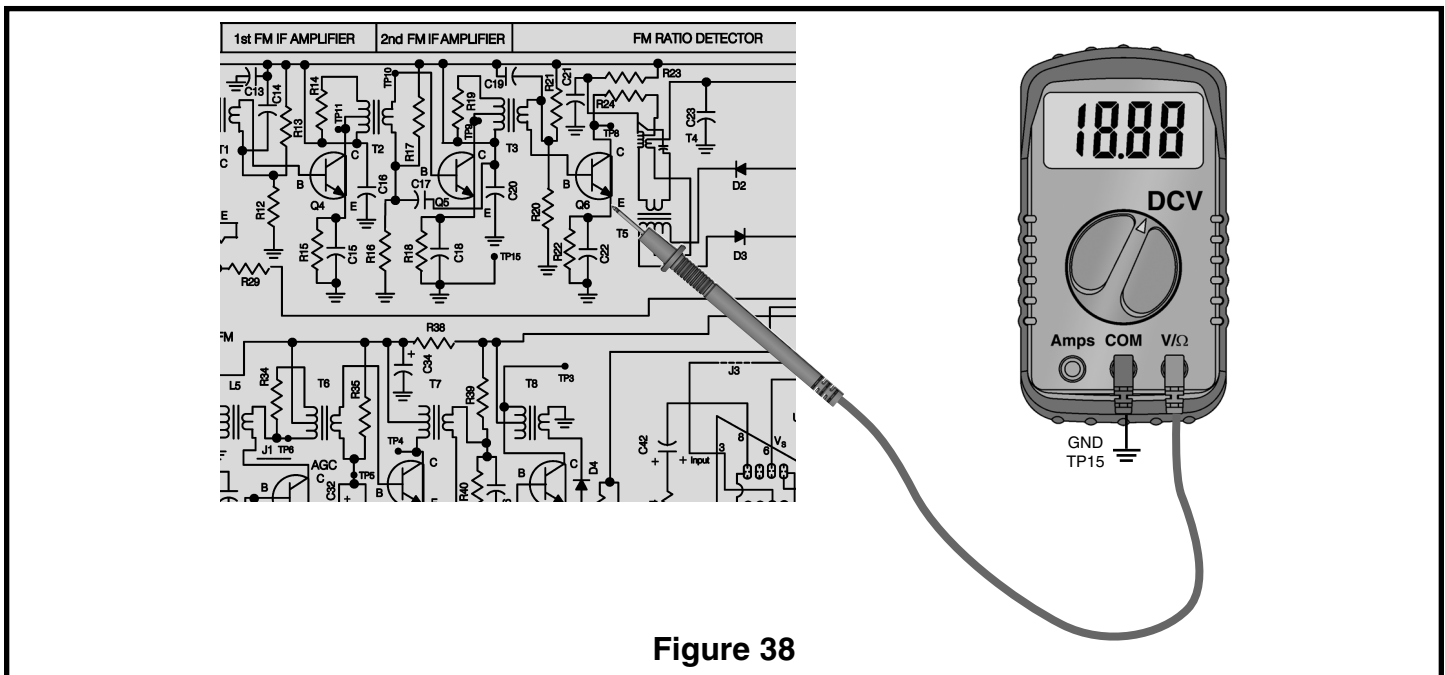

Figure 38

Connect your VOM to the circuit as shown in Figure 38. Turn the power ON. The voltage at the emitter of Q6 should be about 0.7 volts. Record the voltage here:

$$V(Q6) = \underline{\hspace{2cm}}$$

Turn the power OFF. If your answer is greater than 2 volts, check R20, R21, R22, R24, Q6 and the battery.

Since the current through resistor R22 is equal to the current through transistor Q6, calculate the current through Q6 as follows:

$$\text{Current (I)} = V(Q6) / R22$$

Your calculated answer should be between 0.0005 amps (0.5 milliamps) and 0.0011 amps (1.1 milliamps).

$$\text{Current (I)} = \underline{\hspace{2cm}}$$

DYNAMIC MEASUREMENTS

AC GAIN

The AC gain of the ratio detector is set by the AC impedance of the primary side of T4 and the current through Q6. The current is set by R20, R21 and R22. Capacitors C22 and C19 bypass the AC signal to ground. Connect your RF generator and oscilloscope to the circuit as shown in Figure 39.

Your scope probe must have an input capacitance of 12pF or less, otherwise the probe will detune T4 causing an incorrect measurement of the AC gain. Set the generator for 10.7 MHz no modulation and minimum voltage output. Set the scope to read 50mV/division. Turn the power ON and slowly increase the amplitude of the generator until 3 divisions or 150mVpp are seen on the scope. With an alignment tool or screwdriver, adjust T4 for a peak.

Reduce the generator input to maintain 150mVpp on the scope. Move the scope probe to the base of Q6 and record the voltage here:

$$V_b = \text{_____ mVpp.}$$

Turn the power OFF. The AC gain can be calculated as follows:

$$\text{AC Gain} = 150\text{mV} / V_b$$

Your calculated answer should be approximately 20.

Record your calculation:

$$\text{AC Gain} = \text{_____}$$

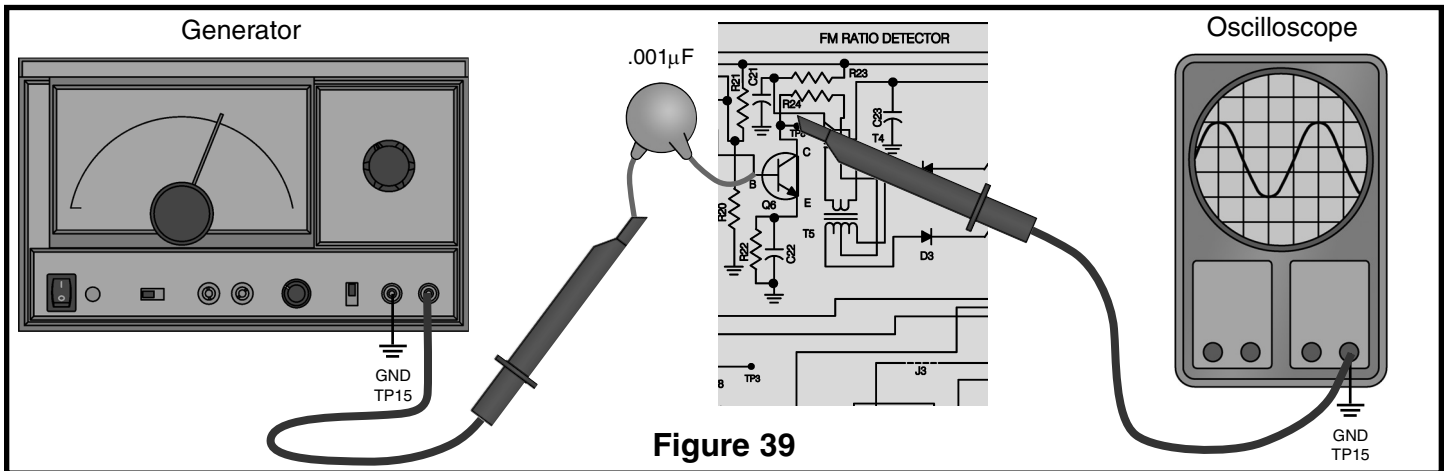

Figure 39

RATIO DETECTOR ALIGNMENT

METHOD #1

ALIGNMENT WITH NO TEST EQUIPMENT

With an alignment tool or a screwdriver, turn both coils T4 and T5 fully counter-clockwise until they

stop. DO NOT FORCE THE COILS ANY FURTHER. Now turn both coils in about 1/4 to 1/2 turns.

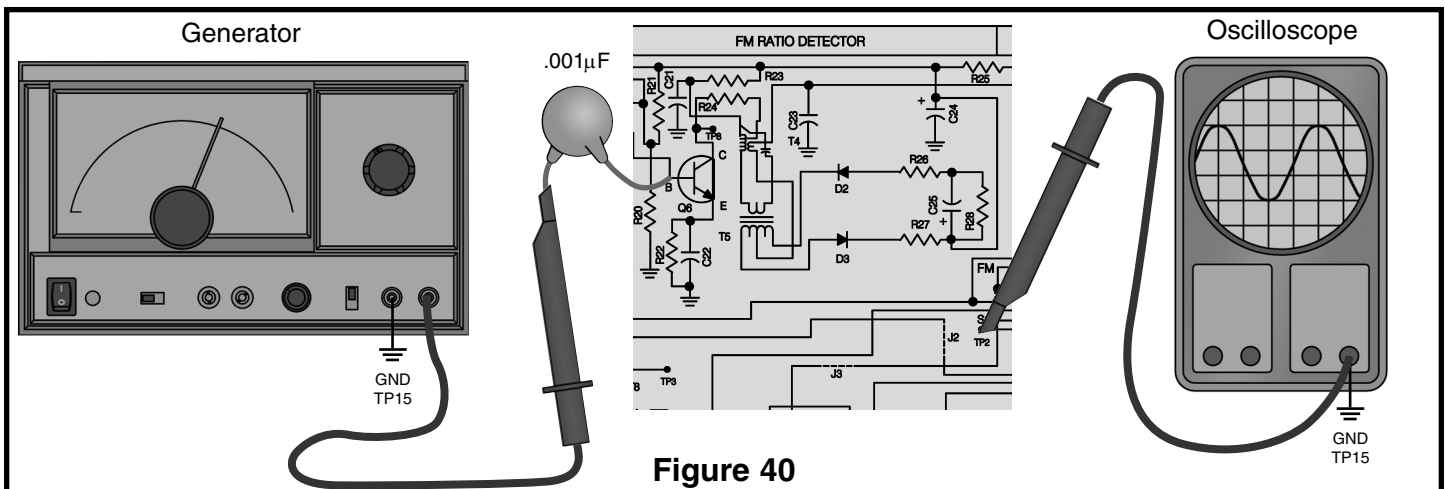

Figure 40

METHOD #2

ALIGNMENT OF RATIO DETECTOR USING A RF GENERATOR AND OSCILLOSCOPE

Connect the RF generator and oscilloscope to the circuit as shown in Figure 40. Set the generator for 10.7MHz modulated at 1kHz, 22.5kHz deviation with minimum voltage out. Turn ON the radio and turn the volume control to the minimum. Slowly increase the amplitude of the generator until a 1kHz sinewave is seen on the scope. With an alignment tool or screwdriver, peak the pink coil T4 for maximum amplitude. Now peak the blue coil T5 for minimum optimized. Turn the power OFF.

METHOD #3

ALIGNMENT OF RATIO DETECTOR USING A SWEEP GENERATOR AND OSCILLOSCOPE

Connect the sweep generator and oscilloscope to the circuit as shown in Figure 40. Set the sweep generator for 10.7MHz and minimum voltage out.

Turn the power ON and set the volume control to a minimum. Increase the amplitude of the sweep generator until an "S" curve is seen (refer to Figure 41). Using an alignment tool or screwdriver, adjust the blue coil T5 until the "S" curve is centered, until each half of the "S" is equal. Repeat these steps until the alignment is optimized. Turn the power OFF.

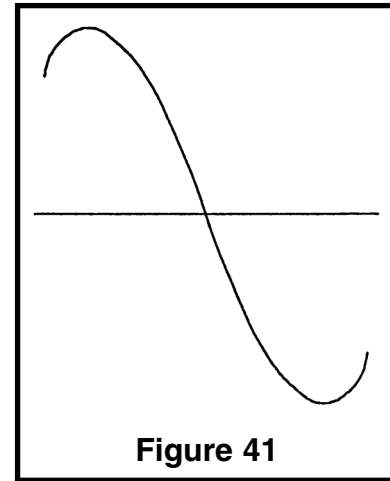

SECTION 7

SECOND FM IF AMPLIFIER

The purpose of the 2nd IF amplifier is to increase the amplitude of the intermediate frequency (IF) while also providing Selectivity. Selectivity is the ability to "pick out" one station while rejecting all others. T3 acts as a bandpass filter that only passes signals around 10.7MHz. The resistor R19 is used to widen

the 3dB bandwidth of the 2nd FM IF amplifier.

The gain at 10.7MHz is fixed by the AC impedance of the primary side of T3 and the current in Q5. The current is fixed by R16, R17 and R18. Capacitors C18 and C17 bypass the AC signal to ground. C20 is a bypass capacitor from V+ to ground.

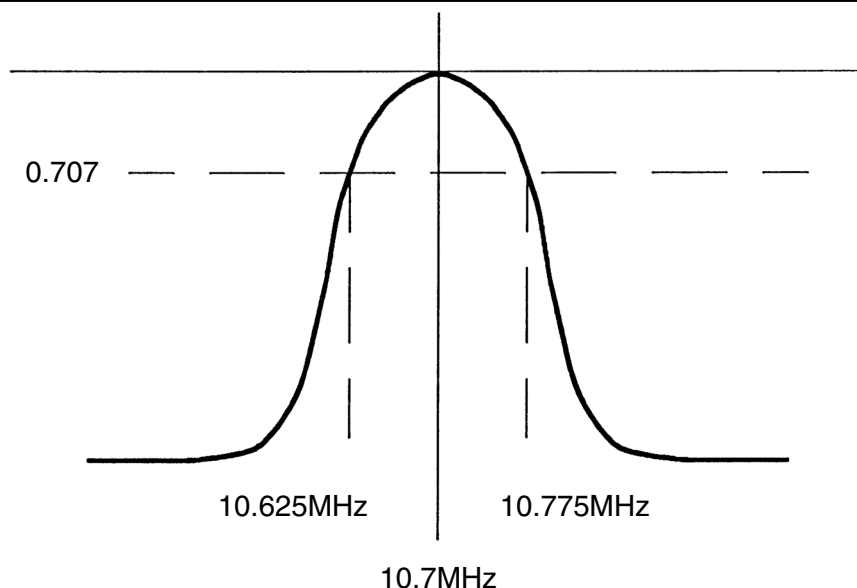
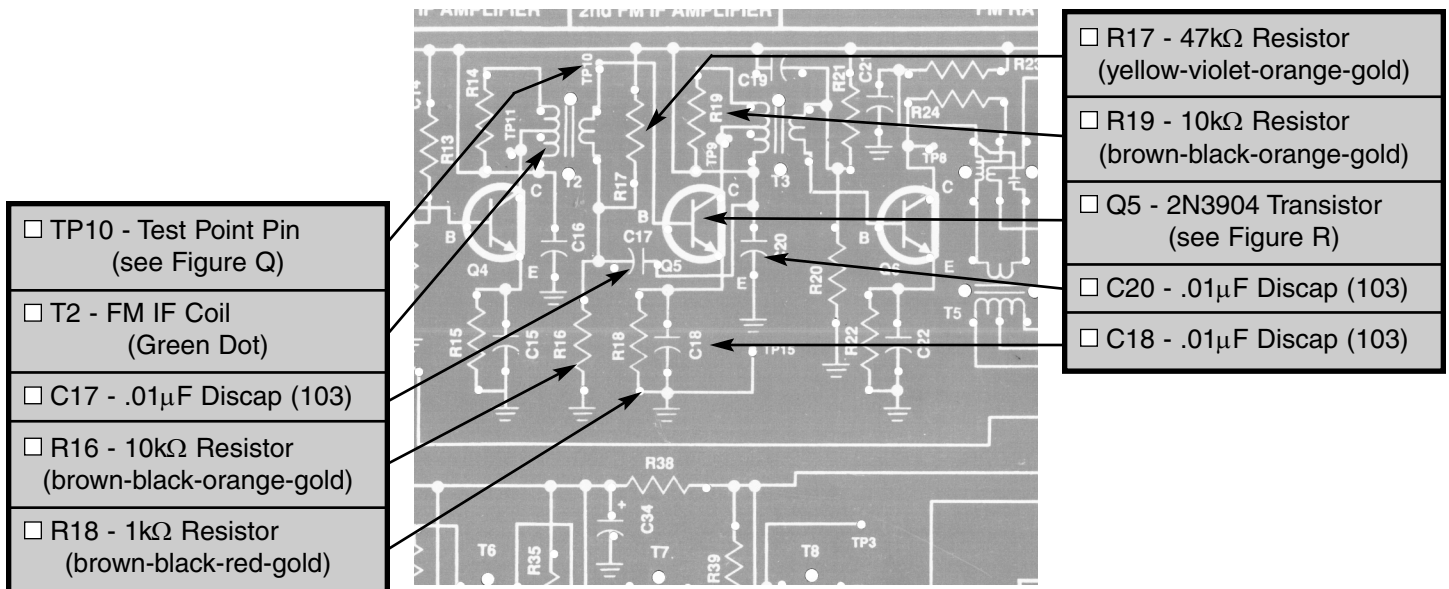

Figure 42

ASSEMBLY INSTRUCTIONS



STATIC TESTS

Q5 BIAS

Connect your VOM to the circuit as shown in Figure 43. Turn the power ON. The voltage at the base of Q5 should be approximately 1.4 volts. Turn the power

OFF. If you do not get this reading, check R17, R16, R18, Q5 and T2.

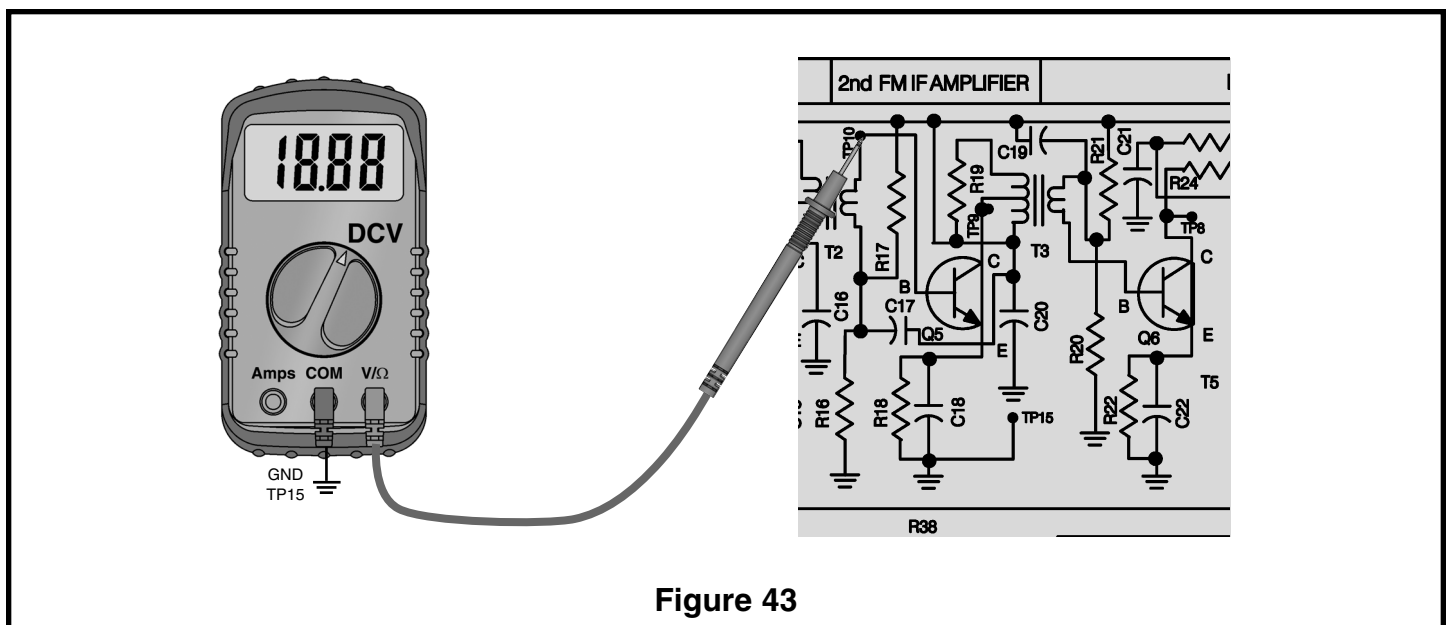

Figure 43

If you don't have an RF generator and oscilloscope, skip to Section 8.

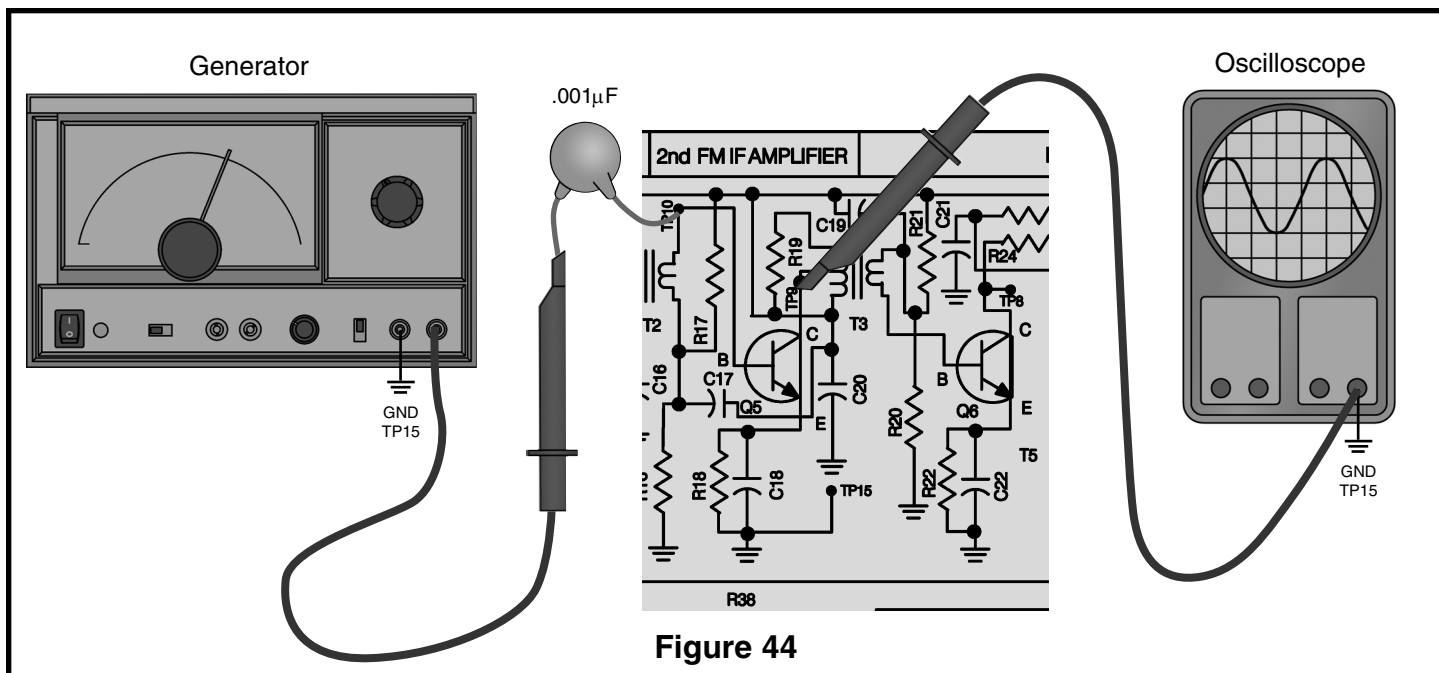

Figure 44

DYNAMIC MEASUREMENTS

AC GAIN

Connect the RF generator and oscilloscope to the circuit as shown in Figure 44. The scope probe must have an input capacitance of 12pF or less otherwise the probe will detune T3 resulting in a false reading of the AC gain. Set the generator at 10.7MHz no modulation and minimum voltage output. Set the scope to read 50mV per division and turn the power ON. Slowly increase the generator until 150mVpp or 3 divisions are seen on the scope. With an alignment tool or screwdriver adjust T3 for a peak. Reduce the generator until 150mVpp or 3 divisions are seen on the scope. With an alignment tool or screwdriver adjust T3 for a peak. Reduce the generator input to maintain 3 divisions on the scope. Move the probe to the base of Q5 and record the input voltage here:

$$V_b = \text{_____ mVpp.}$$

Turn the power OFF. The AC gain can be calculated as follows:

$$\text{AC Gain} = 150\text{mV} / V_b$$

Your calculated answer should be about 20.

Record your calculation:

$$\text{AC Gain} = \text{_____}$$

BANDWIDTH

With the power turned OFF, connect your test equipment as shown in Figure 44. Set your generator at 10.7MHz no modulation and minimum voltage output. Set the scope to read 50mV per division. Turn the power ON and slowly adjust the generator amplitude until 150mVpp is seen on the scope. Realign T3, if necessary, for maximum output while adjusting the generator to maintain 150mVpp. Slowly decrease the frequency of the generator until the voltage drops 0.707 of its original value, 2.1 divisions or 106mVpp. Record the frequency of the lower 3dB drop-off point here:

$$F_l = \text{_____ MHz.}$$

Increase the frequency until the voltage drops to 0.707 of its original value, 2.1 divisions or 106mVpp. Record the frequency of the high frequency 3dB drop-off point here:

$$F_h = \text{_____ MHz.}$$

The bandwidth of the 2nd IF can be calculated as follows:

$$\text{Bandwidth} = F_h - F_l$$

Your results should be between 300 - 500kHz.

Record your calculation:

$$\text{Bandwidth} = \text{_____}$$

SECTION 8

FIRST FM IF AMPLIFIER

The operation of the first IF amplifier is the same as the second IF amplifier except that the gain is different. The gain is set by the AC impedance of the primary side of T2 and the current in Q4. The current in Q4 is set by the resistors R12, R13 and R15.

Capacitors C14 and C15 bypass the AC signal to ground. C13 and C16 are bypass capacitors from V+ to ground to prevent feedback on the V+ line. R19 is used to widen the bandwidth of the transformer T2.

ASSEMBLY INSTRUCTIONS

<input type="checkbox"/> C13 - .01 μ F Discap (103)		<input type="checkbox"/> R13 - 47k Ω Resistor (yellow-violet-orange-gold)
<input type="checkbox"/> C14 - .01 μ F Discap (103)		<input type="checkbox"/> R14 - 10k Ω Resistor (brown-black-orange-gold)
<input type="checkbox"/> T1 - FM Mixer Coil (Orange Dot)		<input type="checkbox"/> TP11 - Test Point Pin (see Figure Q)
<input type="checkbox"/> R12 - 10k Ω Resistor (brown-black-orange-gold)		<input type="checkbox"/> Q4 - 2N3904 Transistor (see Figure R)
<input type="checkbox"/> R15 - 2.2k Ω Resistor (red-red-red-gold)		<input type="checkbox"/> C16 - .01 μ F Discap (103)
		<input type="checkbox"/> C15 - .01 μ F Discap (103)

STATIC TESTS

Q4 BIAS

Connect your VOM as shown in Figure 45. Turn the power ON. The voltage at the base of Q4 should

approximately be 1.4 volts. If you do not get this reading, check R12, R13, R15, Q4 and T1.

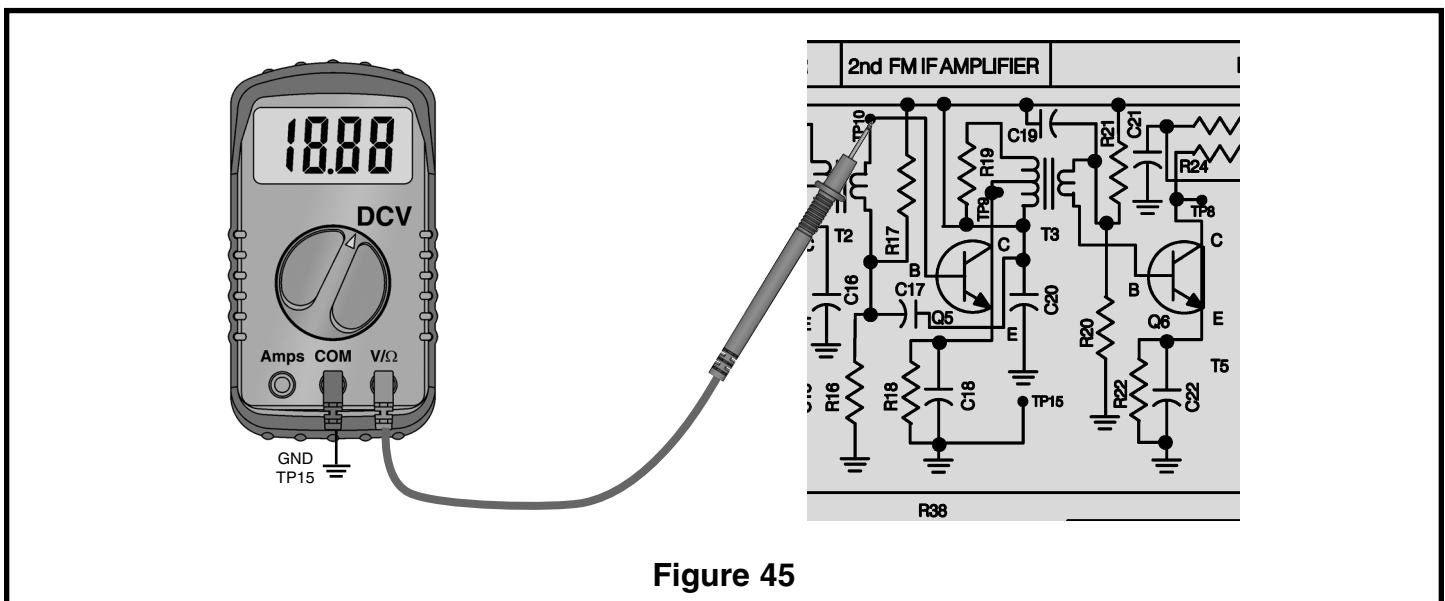

Figure 45

If you don't have an RF generator and oscilloscope, skip to Section 9.

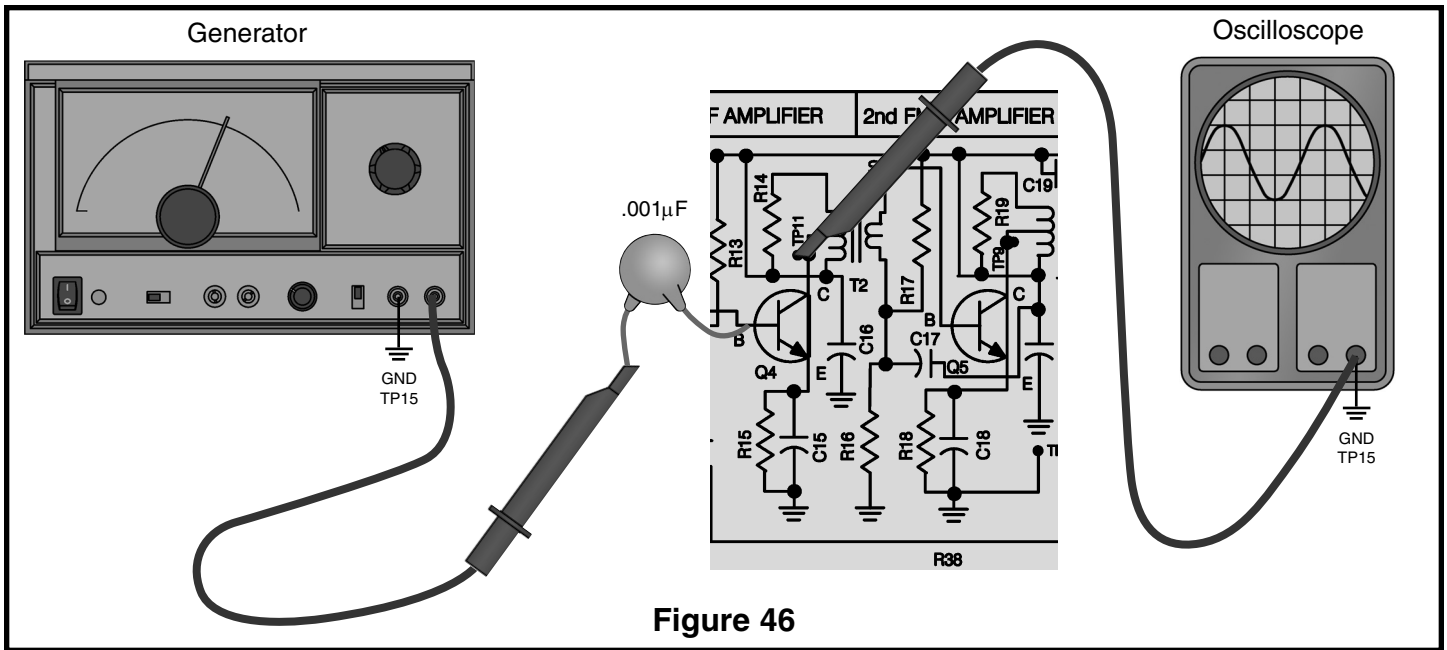

Figure 46

DYNAMIC MEASUREMENTS

AC GAIN

Connect the RF generator and oscilloscope and oscilloscope to the circuit as shown in Figure 46. The scope probe must have an input capacitance of 12pF or less otherwise the probe will detune T2 causing an incorrect measurement of AC gain. Set the generator at 10.7MHz no modulation and minimum voltage output. Set the scope to read 20mV per division and turn the power ON. Slowly increase the amplitude of the generator until 3 divisions or 60mVpp are seen on the scope. With an alignment tool or screwdriver, adjust T2 for a peak. Reduce the generator input to maintain 3 divisions on the scope. Move the scope probe to the base of Q4 and record the input voltage here:

$$V_b = \text{_____} \text{ mVpp.}$$

Turn the power OFF. The AC gain can be calculated as follows:

$$\text{AC Gain} = 60\text{mV} / V_b$$

Your calculated answer should be about 10.

Record your calculation:

$$\text{AC Gain} = \text{_____}$$

BANDWIDTH

Connect your test equipment as shown in Figure 46. Set your generator at 10.7MHz no modulation and minimum voltage output. Set the scope to read 20mV per division. Turn the power ON and slowly increase the amplitude of the generator until 60mVpp is seen on the scope. Increase the frequency of the generator until the voltage drops 0.707 of its original value, 2.1 divisions or 42mVpp.

Record the frequency of the high 3dB drop-off point here:

$$F_h = \text{_____} \text{ MHz.}$$

Decrease the frequency of the generator until the voltage drops to 0.707 of its original value, 2.1 divisions or 42mVpp. Record the frequency of the low 3dB drop-off point here:

$$F_l = \text{_____} \text{ MHz.}$$

The bandwidth of the first IF can be calculated as follows:

$$\text{Bandwidth} = F_h - F_l$$

Your calculated answer should be between 300 - 500kHz.

Record your calculation:

$$\text{Bandwidth} = \text{_____} \text{ kHz.}$$

SECTION 9

FM RF AMPLIFIER, MIXER, OSCILLATOR, AND AFC STAGE

In a superheterodyne receiver, the radio waves are emitted and then mixed with the local oscillator to produce the intermediate frequency (IF). The first stage is the RF amplifier which selects a radio station and amplifies it. The second stage is the local oscillator which oscillates at a frequency 10.7MHz above the desired radio station frequency. The third stage is the mixer stage where the amplified radio waves are heterodyned with the local oscillator. During the mixing process, a difference frequency of 10.7MHz is produced. This difference frequency is used as the IF in FM radios. The collector of transistor Q3 contains an IF transformer (T1) which is tuned only to the difference frequency. This transformer rejects all frequencies except those near

10.7MHz. T1 also couples the 10.7MHz signal to the first FM IF amplifier. The RF amplifier and the oscillator are the only two resonant circuits that change when the radio is tuned for different stations. Since a radio station may exist 10.7MHz above the oscillator frequency, it is important that the RF stage rejects this station and selects only the station 10.7MHz below the oscillator frequency.

The frequency of the undesired station 10.7MHz above the oscillator is called the image frequency. Since this FM receiver has an RF amplifier, the image frequency is reduced significantly. The resistor R9 and capacitor C12 decouple the voltage of the tuner from the voltage of the IF stages.

MIXER ASSEMBLY INSTRUCTIONS

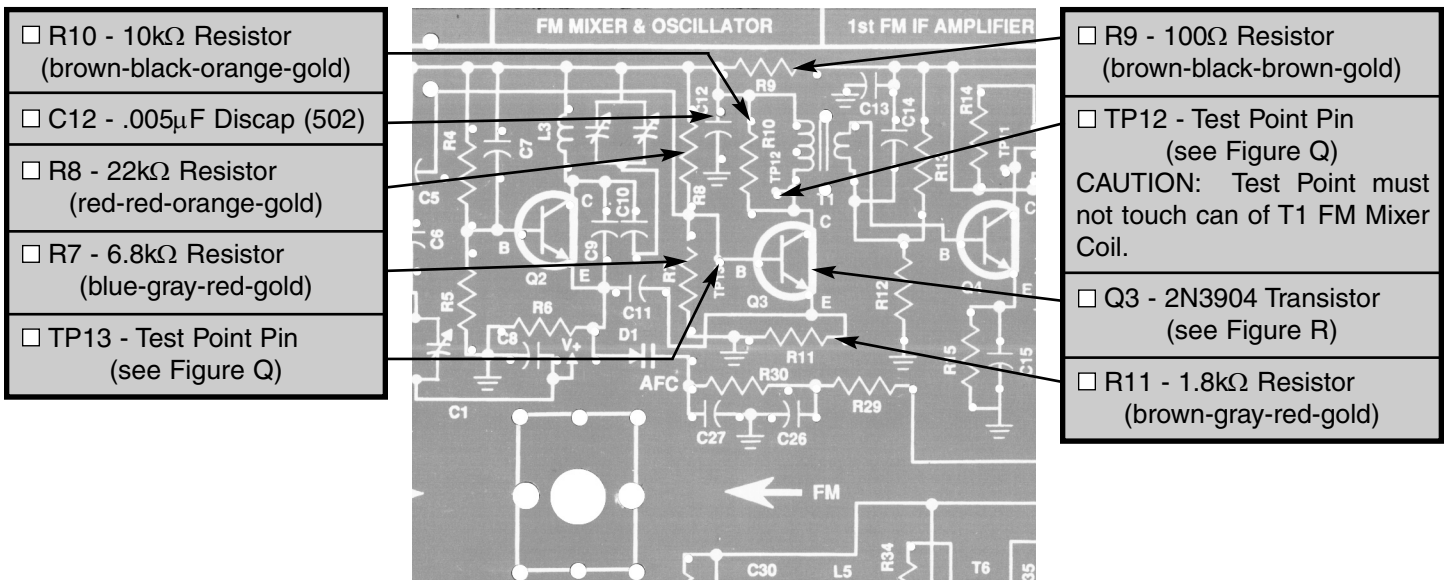

STATIC MEASUREMENTS

Q3 BIAS

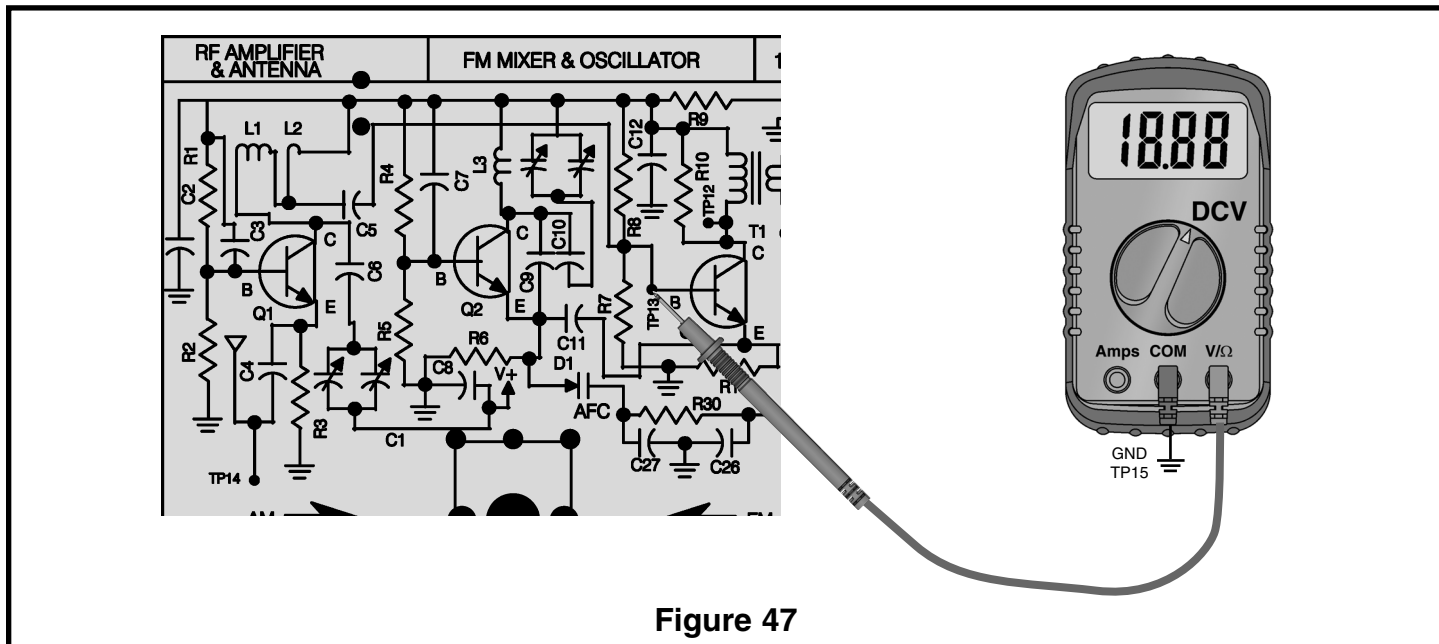

With the power turned OFF, connect your VOM to the circuit as shown in Figure 47. Set your VOM to read 9 volts DC and turn the power ON. The DC voltage at the base of Q3 should be approximately 1.8 volts. If

your answer varies by more than 2 volts, turn the power OFF and check components R7, R8, R11 and Q3.

If you don't have an RF generator and oscilloscope, skip to the FM Oscillator Assembly Procedure.

DYNAMIC MEASUREMENTS

AC GAIN

The AC gain of the mixer is set by the impedance of the primary side of T1 and by the current flowing in Q3. The current in Q3 is set by the resistors R7, R8 and R11. Connect your test equipment to the circuit as shown in Figure 48. Your scope probe must have an input capacitance of 12pF or less, otherwise the probe will detune T1 resulting in an incorrect measurement. Set your scope to read 10mV per division. Set your RF generator at 10.7MHz no modulation minimum voltage output. Turn the power ON and slowly increase the amplitude of the generator until 4 divisions or 40mVpp are seen on the scope. With an alignment tool or a screwdriver, adjust T1 for peak. Reduce the generator amplitude to maintain 4 divisions on the scope. Move the scope probe to the base of Q3 and record the input voltage here:

Vb = _____ mVpp.

Turn the power OFF. The gain can be calculated as follows:

$$\text{AC Gain} = 40\text{mV} / V_b.$$

Your calculated answer should be about 3.

Record your calculation:

$$\text{AC Gain} = \underline{\hspace{2cm}}$$

Because the signal from the oscillator is injected at the emitter of Q3, the emitter resistor is not bypassed to ground. This is why the gain of the mixer is low compared to the other IF stages.

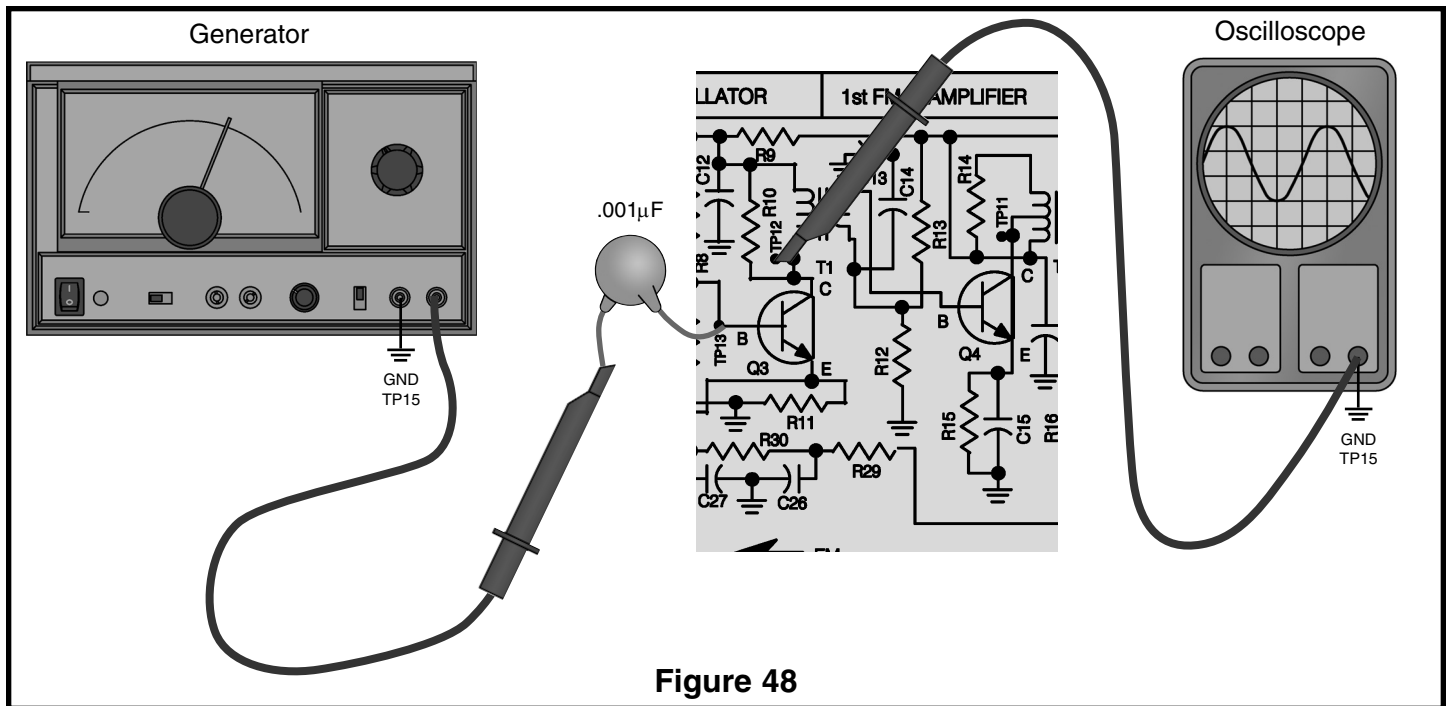

Figure 48

BANDWIDTH TEST

Connect your test equipment to the circuit as shown in Figure 48. Set your generator at 10.7MHz no modulation and minimum voltage output. Set the scope for 10mV per division. Turn the power ON and slowly increase the amplitude of the generator until 40mVpp are seen on the scope. Increase the frequency until the voltage drops 0.707 of its original value, 2.8 divisions or 28mVpp. Record the frequency of the generator until the voltage drops 0.707 of its original value, 2.8 divisions or 28mVpp. Record the frequency of the low 3dB drop-off point here:

Fl = _____ MHz.

Turn the power OFF. The bandwidth can be calculated as follows:

$$\text{Bandwidth} = F_h - F_l$$

Your calculated answer should be between 300 - 500kHz.

Record your calculation:

Bandwidth = _____ kHz.

FM OSCILLATOR ASSEMBLY INSTRUCTIONS

<input type="checkbox"/> C7 - .001µF Discap (102)		<input type="checkbox"/> L3 - FM Oscillator Coil (5 Turns)
<input type="checkbox"/> R4 - 33kΩ Resistor (orange-orange-gold)		<input type="checkbox"/> C9 - 15pF Discap (15)
<input type="checkbox"/> Q2 - 2N3904 Transistor (see Figure R)		<input type="checkbox"/> C10 - 30pF Discap (30)
<input type="checkbox"/> R5 - 33kΩ Resistor (orange-orange-gold)		<input type="checkbox"/> C11 - 220pF Discap (221)
<input type="checkbox"/> R6 - 2.2kΩ Resistor (red-red-gold)		
<input type="checkbox"/> C8 - .005µF Discap (502)		

STATIC MEASUREMENTS

Q2 BIAS

Connect your VOM to the circuit as shown in Figure 49. Set your VOM to read 9 volts and turn the power ON. The voltage at the base of Q2

should be about 4 volts. Turn the power OFF. If you do not get this measurement, check R4, R5 and Q2.

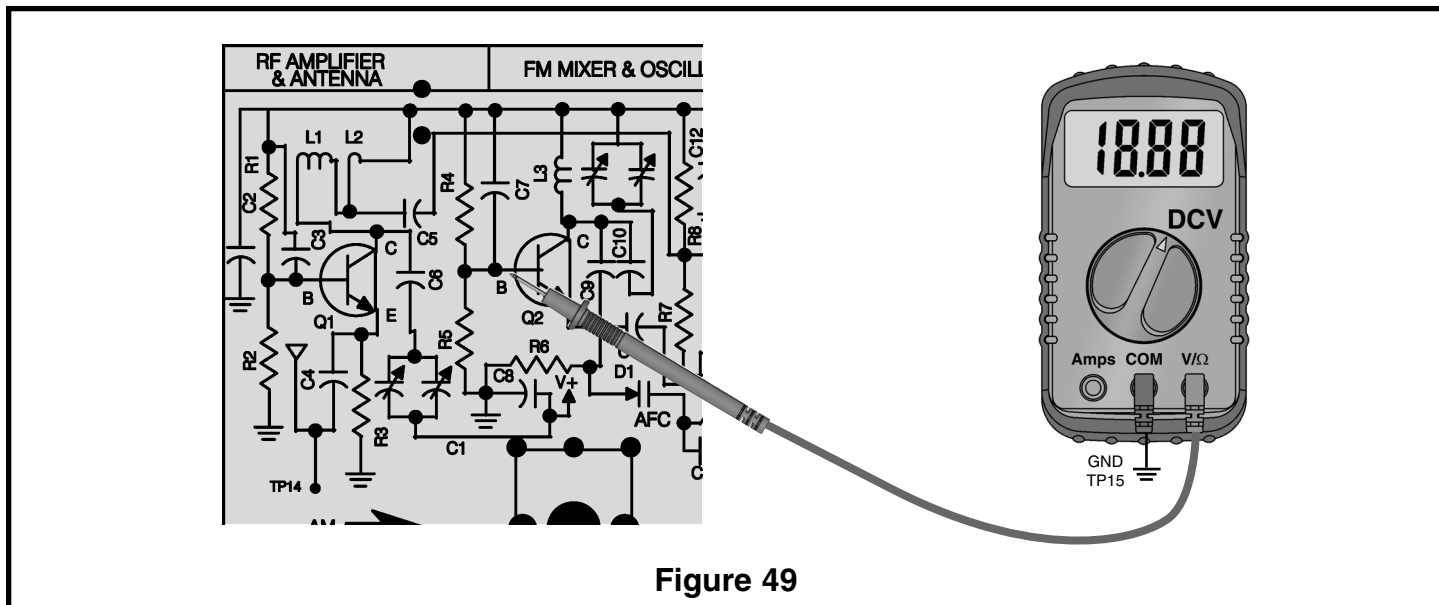

Figure 49

AFC

When a radio is tuned to a station, it would be desirable for the radio to “lock” in on the station. Due to changes in temperature, voltage and other effects, the local oscillator may change its frequency of oscillation. If this occurs, the center frequency of 10.7MHz will not be maintained. Automatic Frequency Control (AFC) is used to maintain the 10.7MHz center frequency. When the local oscillator drifts, the ratio detector will produce a DC “correction” voltage. The audio signal rides on this DC correction voltage. This signal is fed to a filter network which removes the audio so that a pure DC voltage is produced. This voltage is fed to a special

diode called a varactor. A varactor will change its internal capacitance when a voltage is applied. The ratio detector diodes are positioned in such a way that when the 10.7MHz center frequency increases, the DC correction voltage will decrease. Likewise, when the 10.7MHz center frequency decreases, the DC correction voltage will increase. This voltage change causes the capacitance of the varactor to change. The varactor is connected at the emitter of Q2, so any capacitance change in the varactor is seen at the emitter of the oscillator. A change in capacitance at the emitter of Q2 will change the frequency of oscillation of the local oscillator.

AFC ASSEMBLY INSTRUCTIONS

- R30 - 390k Ω Resistor (orange-white-yellow-gold)
- D1 - Varactor Diode (see Figure T)
- C27 - .001 μ F Discap (102)

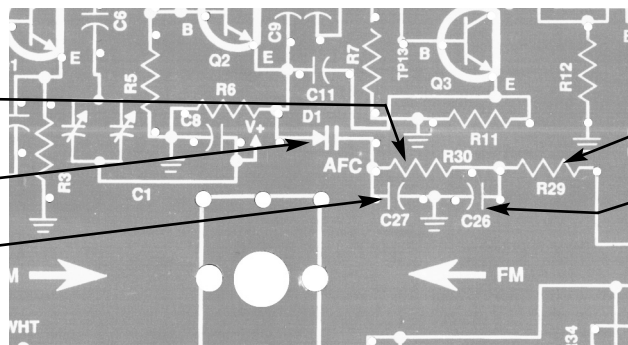

- R29 - 390k Ω Resistor (orange-white-yellow-gold)
- C26 - .1 μ F Discap (104)

If you don't have an RF generator, skip to the RF Amplifier Assembly Procedure.

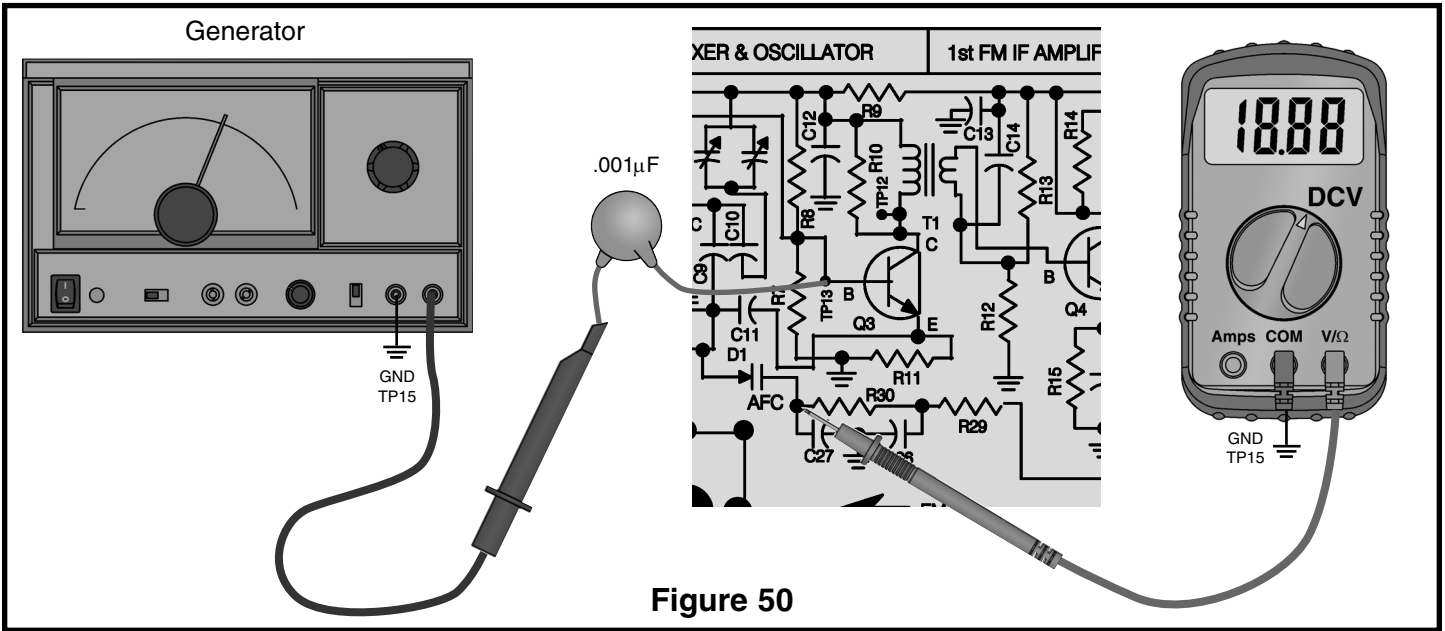

Figure 50

Connect the RF generator and VOM to the circuit as shown in Figure 50. Set your VOM to read 9 volts DC. Set your generator at 10.7MHz no modulation and moderate signal strength output. Turn the power ON. Record the voltage of D1 here:

V(D1) = _____.

While watching your VOM, slowly decrease the frequency of your generator. As the frequency decreases, the voltage at D1 should increase.

Increase the frequency of the generator until the voltage is equal to V(D1). While watching your VOM, increase the frequency of your generator. As the frequency increases, the voltage at D1 should decrease. This correction voltage is what keeps the oscillator from drifting. If the voltage at D1 still does not change at D1, check D1, R29, R30, C26 and C27. If these parts are inserted correctly and the voltage at D1 still doesn't change, then increase the amplitude of your generator and repeat the same steps again. Turn the power OFF.

RF AMPLIFIER ASSEMBLY INSTRUCTIONS

<input type="checkbox"/> R1 - 22kΩ Resistor (red-red-orange-gold)		<input type="checkbox"/> L1 - FM RF Amp Coil (6 Turns) see Figure V
<input type="checkbox"/> C3 - .001µF Discap (102)		<input type="checkbox"/> L2 - FM RF Amp Coil (2 Turns) see Figure V
<input type="checkbox"/> C2 - .005µF Discap (502)		<input type="checkbox"/> C5 - 470pF Discap (471)
<input type="checkbox"/> Q1 - 2N3904 Transistor (see Figure R)		<input type="checkbox"/> C6 - 33pF Discap (33)
<input type="checkbox"/> R2 - 6.8kΩ Resistor (blue-gray-red-gold)		<input type="checkbox"/> R3 - 470Ω Resistor (yellow-violet-brown-gold)
<input type="checkbox"/> C4 - 470pF Discap (471)		<input type="checkbox"/> TP14 - Test Point Pin (see Figure Q)

Figure V

STATIC MEASUREMENTS

Q1 BIAS

Connect your VOM to the circuit as shown in Figure 51. Set your VOM to read 9 volts and turn the power ON. The voltage at the base of Q1 should be about 1.6 volts. If you do not get this reading, check R1, R2, R3 and Q1. Turn the power OFF.

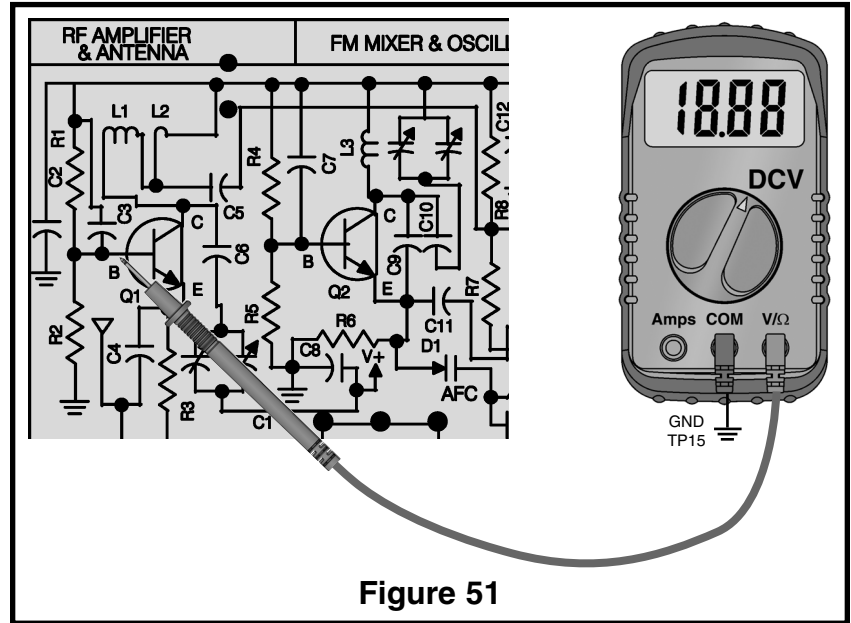

ANTENNA FM ASSEMBLY

- Antenna FM
- 2 Screw M2 x 5mm (antenna)
- 2½" Wire #22AWG Insulated (extra wire in AM Section) (see Figure W)

Mount the antenna to the PC board with two screws as shown. **NOTE: Some antennas have only one threaded hole.**

Cut a 2½" wire and strip ¼" of insulation off of both ends of the remaining jumper wire. There are no holes for the wire in this location, so tack solder the wire to the pads as shown.

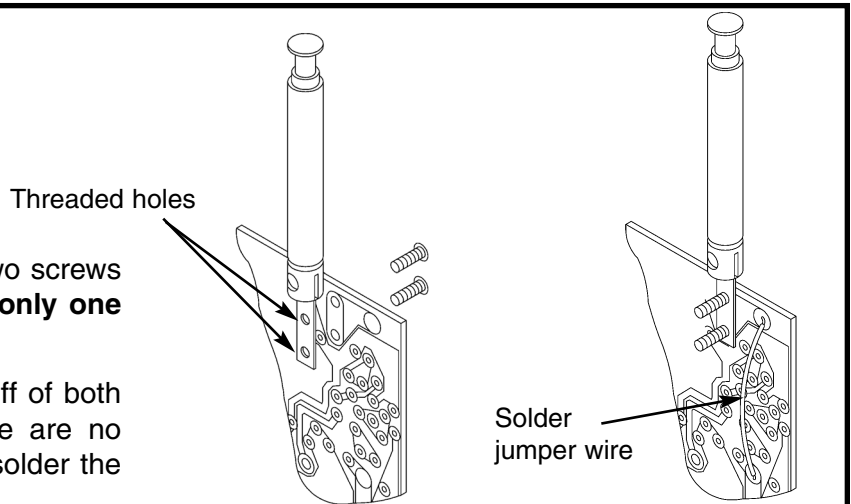

Figure W

FM FINAL ALIGNMENTS

There are two procedures for the final alignment steps. The first alignment procedure is for those who do not have test equipment and the second is for those who do have test equipment.

Your "magic wand" will be used to align the FM oscillator circuit and the FM RF amplifier. When the brass end of your "magic wand" is placed near the FM oscillator coil L3, the coil reacts as if inductance has been removed. Likewise, when the iron end of the "magic wand" is placed near the coil L3, it reacts as if inductance has been added. The same is true for the RF coils L1 and L2. When the inductance of a

resonant circuit is changed, the resonant frequency is changed also.

When aligning the oscillator, changing the resonant frequency changes the frequency of oscillation. Likewise, when aligning the RF amp, changing the resonant frequency at which it was selective.

When aligning the oscillator and RF circuits, coils L1 and L3 will be adjusted at the lower end of the band, while the oscillator and RF trimmer capacitors are adjusted at the higher end of the band. This is done so that the RF amp tracks the oscillator properly.

ALIGNMENT WITH NO TEST EQUIPMENT

With an alignment tool or screwdriver turn coils T1, T2 and T3 fully counter-clockwise. DO NOT FORCE

THE COILS ANY FURTHER. Turn each coil in about 1¼ to 1½ turns.

IF ALIGNMENT

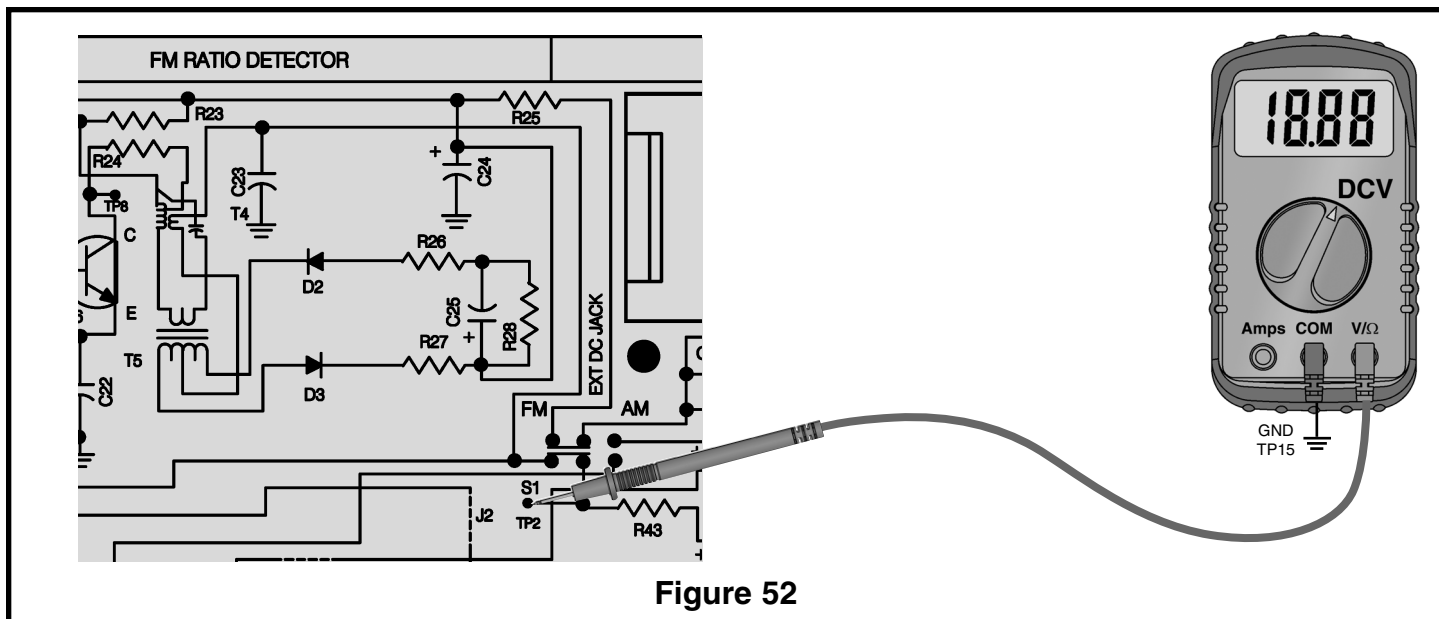

Figure 52

With an alignment tool or screwdriver turn coils T1, T2 and T3 fully counter-clockwise. DO NOT FORCE THE COILS ANY FURTHER. Turn each coil in about 1¼ to 1½ turns.

Use the earphone provided for best results. Switch to the FM position. Connect your VOM to the circuit as shown in Figure 52. Turn the radio ON and tune the radio to a weak station. It is best to keep the volume at a low level. Adjust T1 for the minimum voltage on your VOM. Reduce the volume if necessary. Adjust T2 for minimum voltage on your VOM and reduce the volume control if necessary. Adjust T3 for minimum voltage on your VOM and reduce the volume control if necessary. As you adjust the coils you should hear less distortion and noise. Repeat this procedure until the FM IF gain is optimized. This process peaked the FM IF amplifier to their maximum gain.

DETECTOR ALIGNMENT

Adjust T4 for minimum voltage on your VOM. Adjust T5 for minimum distortion. Repeat these 2 steps until the ratio detector alignment is optimized.

OSCILLATOR ALIGNMENT

Tune the radio to a known station around 90MHz. Once a station is found and its broadcast frequency is known, rotate the dial until the white pointer is aligned with that stations frequency on the dial. Using the "magic wand", place the brass end near coil L3. Refer to Figure 53.

If the station is heard, this means that L3 needs less inductance. Carefully pull apart L3 until the station is heard. Place the iron end near L3. If the station is heard, this means that L3 needs more inductance. Carefully press together L3 until the station is heard. Pulling apart or pressing together L3 just a small amount will have a great effect on the coils resonant frequency. Repeat this step until the pointer is aligned to the station's frequency. Tune the radio to a station around 106MHz. Once a station is found and its broadcast frequency is known, rotate the dial until the white pointer is aligned with that station's frequency on the dial. Place the brass end of the "magic wand" near L3. If the station is heard, it means that L3 needs more capacitance. Carefully adjust the FM oscillator trimmer (as shown in Figure N, page 32), on the back of the gang until the station

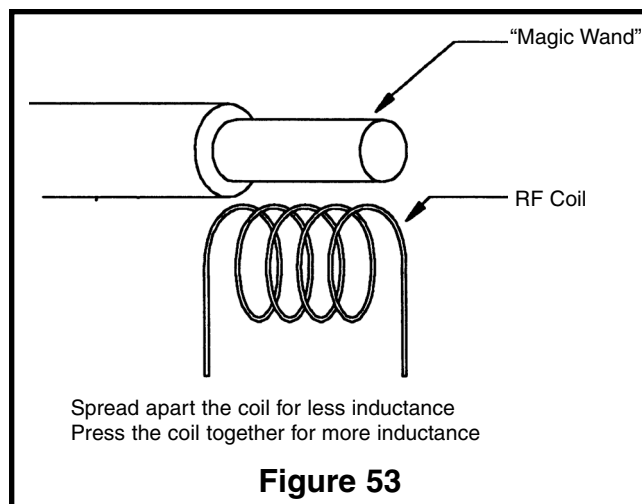

Figure 53

is heard. Place the iron end of the “magic wand” near L3. If the station is heard, it means that L3 needs less capacitance. Carefully adjust the FM oscillator trimmer located on the back of the gang until the station is heard. Repeat this step until the pointer is aligned to the station’s frequency. Adjusting both the oscillator coil L3 and the oscillator trimmer capacitor will effect the oscillator’s frequency, so it is advisable to repeat this procedure until the FM oscillator alignment is optimized. This process sets the FM oscillator range at 98.7MHz to 118.7MHz.

RF ALIGNMENT

Press together L1 and L2. Spread apart coil L1 so that it resembles Figure 54. The gaps or spaces should be between 1/32” and 1/16” wide. This procedure sets the tracking of the RF section. Use the special coil spacer provided to gap the coil as shown. Carefully slide the coil spacer between the coils to get the spacing shown in Figure 54.

This concludes the alignment of the FM radio section. If no stations are heard, verify that FM signals are present in your location by listening to another FM radio placed near the superhet 108. If the FM section is still not receiving go back and check each stage for incorrect values and for poor soldering.

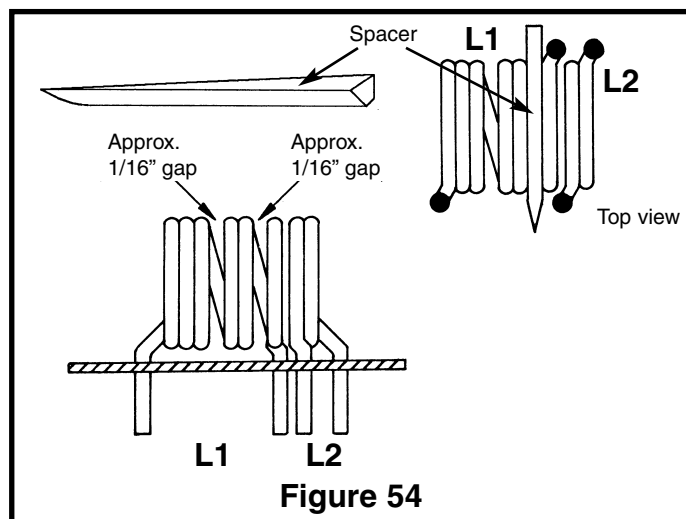

ALIGNMENT WITH RF GENERATOR AND OSCILLOSCOPE

IF ALIGNMENT

Switch to the FM section. Connect your RF generator and oscilloscope to the circuit as shown in Figure 55. Set your RF generator at 10.7MHz modulated at 1kHz deviation with minimum voltage output. Set the

scope to read 50mV per division. With a clip lead, short the base emitter junction of Q2. This short “kills” the local oscillator.

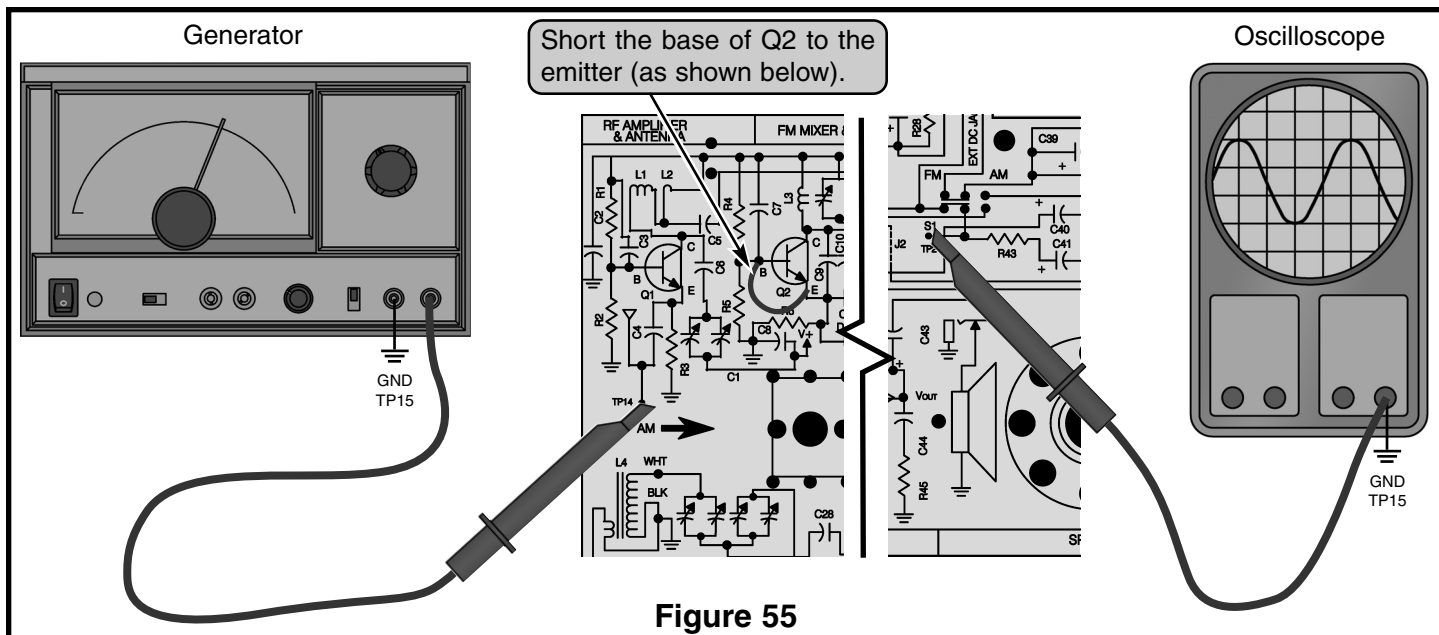

Turn the power ON. Slowly increase the amplitude of the generator until a 1kHz signal is seen on the scope. Keep the generator at a low level of output to prevent the IF sections from limiting. With an alignment tool or screwdriver, adjust T1 for a peak on

the scope. Reduce the amplitude of the input signal if necessary. Adjust T2 for a peak and reduce the amplitude of the input signal if necessary. Repeat these steps until the IF alignment is optimized. This procedure aligns the FM IF amplifiers to 10.7MHz.

OSCILLATOR ALIGNMENT

Remove the clip lead and set your generator at 88MHz modulator at 1kHz, 22.5kHz deviation and minimum voltage output. Tune the radio until a 1kHz signal is seen on the scope. It may be necessary to increase the amplitude of the generator. Rotate the dial until the white pointer is aligned to 88MHz. Using the “magic wand” place the brass end near L3 as shown in Figure 53. If the signal seen on the scope increases, this means L3 needs less inductance. To remove inductance, carefully spread apart coil L3. Pulling apart or pressing together coil L3, a small amount will have a great effect on the coil’s resonant frequency. Place the iron end of the “magic wand” near L3. If the signal seen on the scope increases, it means L3 needs more inductance. To add inductance carefully press together coil L3. Repeat these steps until the signal decreases for both ends of the “magic wand”. Increase the frequency of your generator to 108MHz. Tune the radio until a 1kHz signal is seen on the scope. Rotate the dial until the white pointer is aligned to 108MHz. Place the brass end of your “magic wand” near L3. If the signal on the scope increases, it means that L3 needs more capacitance. Adjust the FM oscillator trimmer on the gang (as shown in Figure N on page 32) until the 1kHz signal is at a peak. Place the iron end of the “magic wand” near L3. If the signal increases, it means that coil L3 needs less capacitance. Adjust the FM oscillator trimmer on the gang until the 1kHz signal is at a peak. Repeat these 2 steps until the signal decreases for both ends of the “magic wand”. Since adjusting both the oscillator coil L3 and the oscillator trimmer will effect the frequency of oscillation, it is advisable to repeat this procedure until the oscillator alignment is optimized. This process sets the FM oscillator range at 98.7MHz to 118.7MHz.

RF ALIGNMENT

Set your generator at a frequency around 90MHz modulated at 1kHz, 22.5kHz deviation and minimum voltage out. Tune your radio until a 1kHz tone is heard. Place the brass end of your “magic wand” near RF coil L1. If the signal on the scope increases, it means that coil L1 needs less inductance. Carefully spread apart the coil L1 to reduce its inductance. Place the iron end of the wand near L1. If the signal increases, it means that coil L1 needs more inductance. Carefully press together the coil L1 to increase its inductance. Repeat these steps until the signal on the scope decreases for both ends of the “magic wand”. Increase your generator to a frequency near 106MHz. Tune your radio until a 1kHz tone is heard. Place the brass end of your “magic wand” near L1. If the signal increases, it means that the coil L1 needs more capacitance. With an alignment tool or screwdriver, adjust the FM antenna trimmer (see Figure N on page 32). If the signal increases, this means coil L1 needs less capacitance. Carefully adjust the FM antenna trimmer until a peak is seen on the scope. Repeat these steps until the signal on the scope decreases for both ends of the “magic wand”. Since adjusting both the RF coil L1 and the antenna trimmer will effect the gain of th RF stage, it is advisable to repeat this procedure until the RF amplifier alignment is optimized. This process sets the RF stage to “track” the FM oscillator stage.

This concludes the alignment of the FM radio section. If no stations are heard, verify that FM signals are present in your location by listening to another FM radio near the Superhet 108. If the FM section is still not receiving, go back and check each stage for incorrect values and for poor soldering.

FM RADIO HIGHLIGHTS

1. The FM broadcast band covers the frequency range from 88MHz to 108MHz.
2. Audio signals up to 15kHz are transmitted on the FM carrier.
3. The amount that the RF carrier changes frequency is determined by the amplitude of the modulating signal.
4. The number of times the carrier frequency changes in a period of time is exactly equal to the audio frequency.
5. The change in frequency is called the deviation and is limited to 75kHz for monaural FM.
6. The bandwidth assigned for FM is 200kHz.

DC VOLTAGES

The voltage readings below should be used in troubleshooting the FM section (Switch at FM position.)

Q1	B	1.6	Q4	B	1.3
	E	.9		E	.7
	C	7.0		C	7.5
Q2	B	3.3	Q5	B	1.3
	E	3.0		E	.6
	C	7.1		C	7.5
Q3	B	1.6	Q6	B	1.2
	E	1.3		E	.6
	C	7.0		C	6.6

Test Conditions

1. Volume set to minimum.
2. Connect TP14 to TP15 with a jumper wire.
3. Battery voltage = 9V
4. All voltages are referenced to circuit common.
5. Voltage readings can vary $\pm 10\%$

SPECIFICATIONS

Audio:

Frequency response 3dB drop into 8 ohm resistive load.

Low end 800Hz - high end 120kHz

Maximum power out at 10% total harmonic distortion.

500 MilliWatts

Typical audio gain at 1000Hz: 150 times

Typical % distortion at 100 milliwatts output <2%.

AM Radio Specifications:

Tuning range - 520kHz to 1620kHz

IF frequency 455kHz

Tracking = ± 3 dB from 700kHz to 1400kHz

10dB signal to noise at 200 microvolts typical

FM Radio Specifications:

Tuning range = 88MHz to 108MHz

IF frequency 10.7MHz

Tracking ± 5 dB from 90MHz to 106MHz

10dB signal to noise at 12 microvolts typical

Uses ratio detector and full time auto frequency control.

QUIZ - FM RADIO SECTION

INSTRUCTIONS: Complete the following examination, check your answers carefully.

1. The FM broadcast band is . . .
 - A) 550 - 1,600kHz.
 - B) 10.7MHz.
 - C) 88 - 108MHz.
 - D) 98.7 - 118.7MHz.
2. The maximum audio frequency used for FM is ...
 - A) 7.5kHz.
 - B) 15kHz.
 - C) 20kHz.
 - D) 10.7MHz.
3. The frequency of the modulating signal determines the . . .
 - A) number of times the frequency of the carrier changes per second.
 - B) maximum deviation of the FM carrier.
 - C) maximum frequency swing of the FM carrier.
 - D) amount of amplitude change of the FM carrier.
4. The AFC circuit is used to ...
 - A) automatically hold the local oscillator on frequency.
 - B) maintain constant gain in the receiver to prevent such things as fading.
 - C) prevent amplitude variations of the FM carrier.
 - D) automatically control the audio frequencies in the receiver.
5. The ratio detector transformer is tuned to ...
 - A) 10.7MHz.
 - B) 88MHz.
 - C) 455kHz.
 - D) 10.9MHz.
6. The ratio detector is used because ...
 - A) it is sensitive to noise.
 - B) it is insensitive to noise.
 - C) it provides amplification.
 - D) it doesn't need a filter.
7. The device most often used for changing the local oscillator frequency with the AFC voltage is a ...
 - A) feedthrough capacitor.
 - B) variable inductor.
 - C) varactor.
 - D) trimmer capacitor.
8. The capacitance of a varactor is determined by ...
 - A) the voltage level.
 - B) the amount of current in the circuit.
 - C) the signal strength of the RF carrier.
 - D) the amount of resistance in the circuit.
9. Limiting in FM receivers is the process of ...
 - A) removing interfering FM stations.
 - B) providing greater station selectivity.
 - C) separating the FM stations from the AM stations.
 - D) removing noise from the FM carrier.
10. A detector circuit that does not require a limiter is a ...
 - A) slope detector.
 - B) ratio detector.
 - C) Travis detector.
 - D) Foster-Seeley detector.

Answers: 1. C, 2. B, 3. A, 4. A, 5. A, 6. B, 7. C, 8. A, 9. D, 10. B

AM/FM-108 Radio Baffle

NOTICE: Keep the box the kit came in. After you have completed the radio and it operates satisfactorily, you may want to install a baffle to improve the sound.

The final step in the radio kit will be to assemble and attach a baffle to the speaker. You will need to remove the baffle located in the bottom of the box. If it does not want to come out easily, use a knife to cut the holding tabs.

When a speaker is not enclosed, sound waves can travel in all directions. As a speaker moves outward,

it creates positive pressure on the air in front of it and negative pressure on the rear. At low frequencies, out of phase front and rear waves mix causing partial or total cancellation of the sound wave. The end result is a speaker less efficient and distorted.

To eliminate the low frequency cancellation, a speaker is placed inside an enclosure. Now the front sound wave are prevented from traveling to the back. The speaker will now compress and decompress air inside, increasing its resonant frequency and Q relative to the free air values. This type of effectively air-tight box is called an Acoustic Suspension.

<input type="checkbox"/> 2 Screws M1.8 x 7.5mm
<input type="checkbox"/> 2 Nuts M1.8
<input type="checkbox"/> Baffle

1. Start at one edge and carefully remove the baffle from the bottom the kit box.

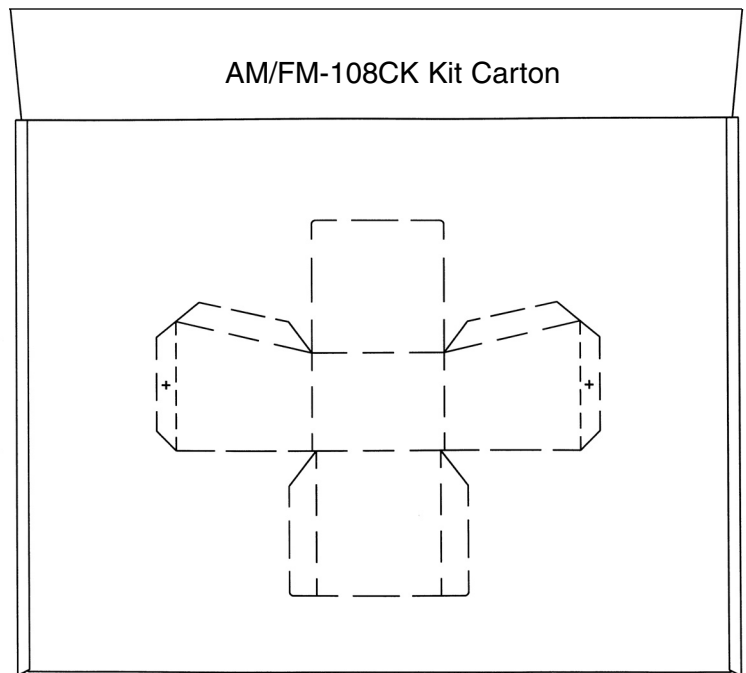

2. Bend the four flaps upward as shown.

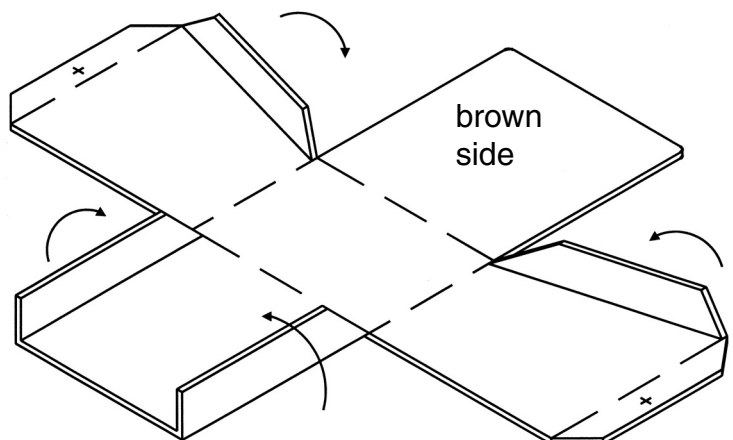

3. Bend the top side upward as shown.

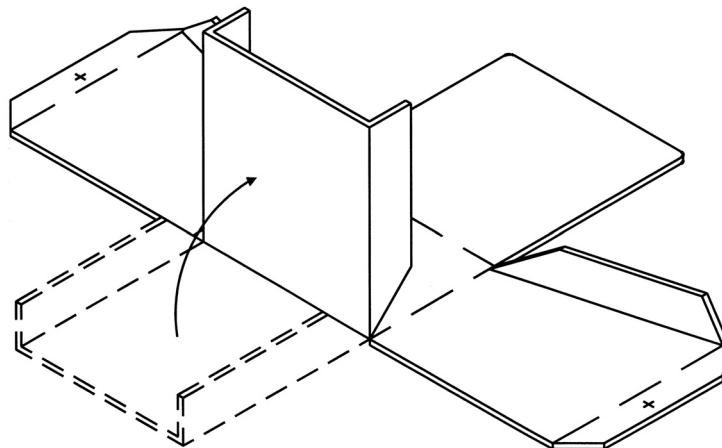

4. Bend the two sides upward. Attach the three sides using scotch tape or glue (Elmer's, Duco Cement, or other).

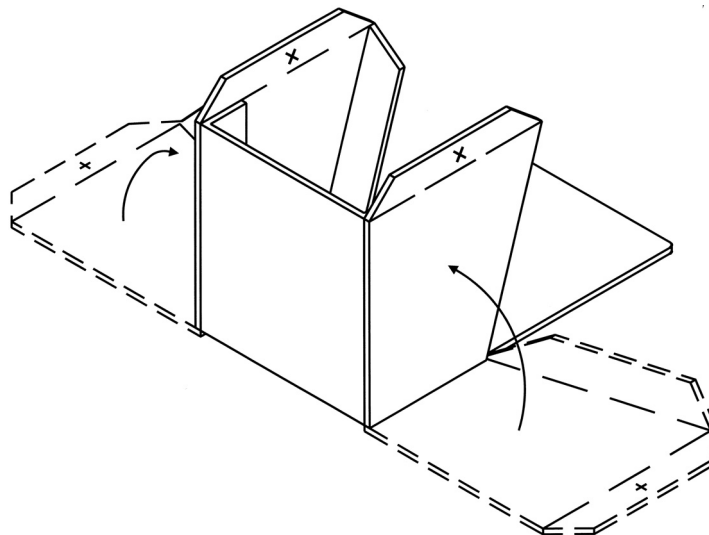

5. Bend the bottom side upward and attach it to the other sides using scotch tape or glue. Bend the two mounting flaps down.

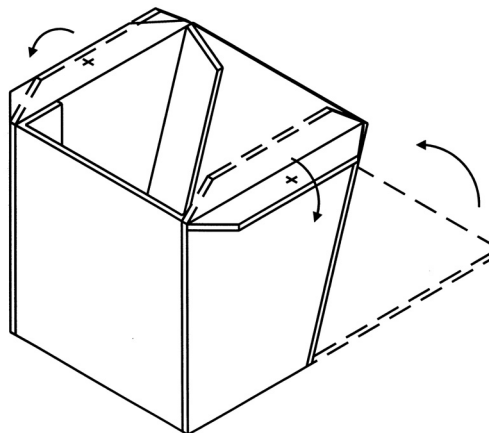

6. Place the baffle over the speaker. Align the mounting holes and attach it using the two screws and two nuts supplied. The screws should go through the X mark on the baffle flap.

Optional: To make an air tight seal, place a bead of glue between the PC board and the baffle edges.

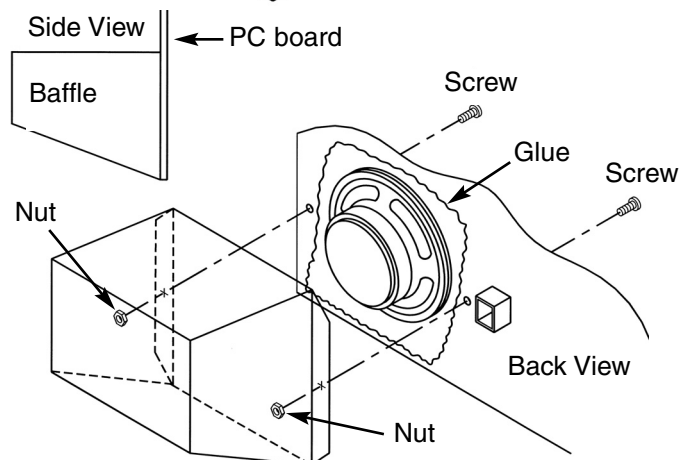

SCHEMATIC DIAGRAM - AM/FM RADIO

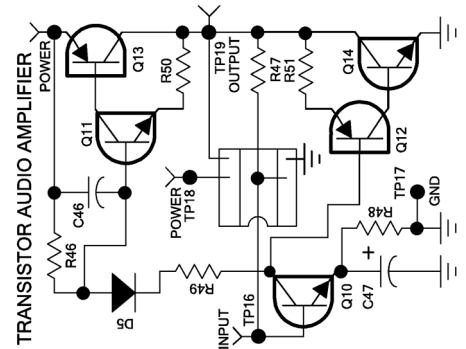
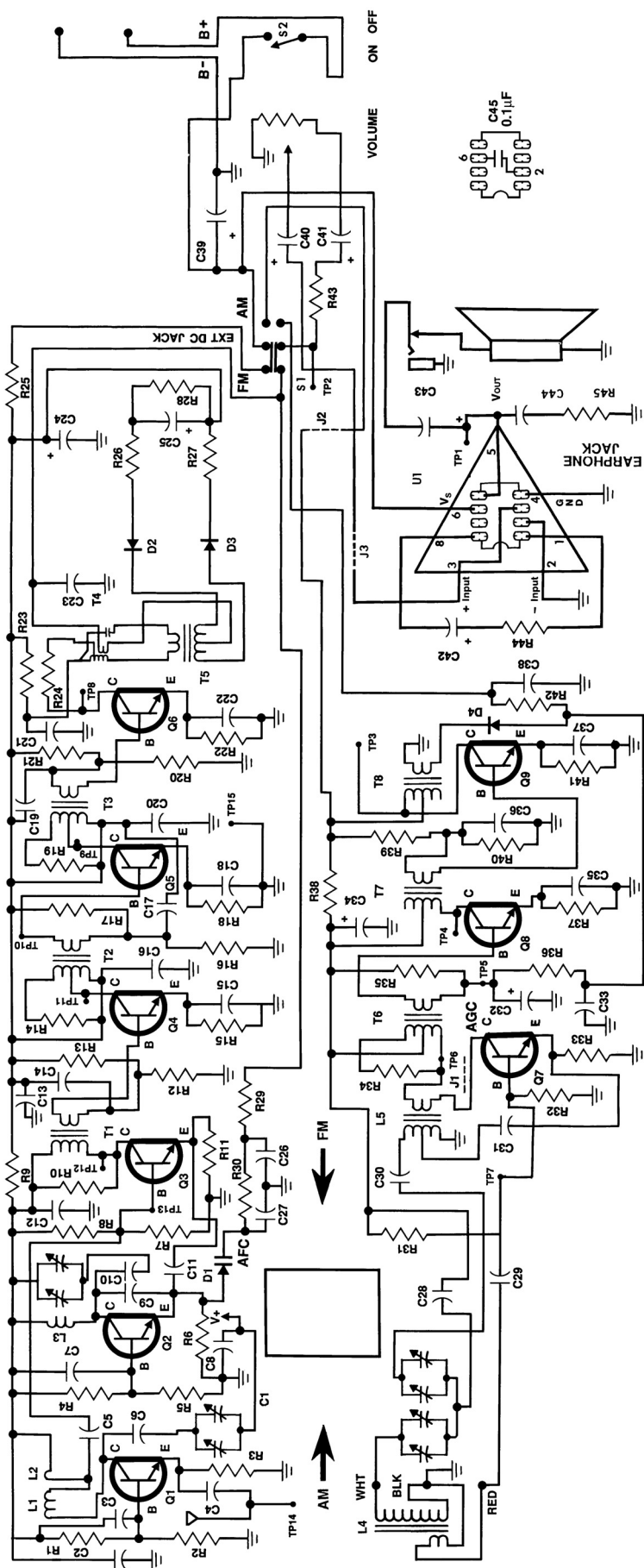

 **ELENCO®**
 150 Carpenter Avenue
 Wheeling, IL 60090
 (847) 541-3800
 elenco.com
 e-mail: elenco@elenco.com